

MC6-T

Multifunction Temperature Calibrator and Communicator



Applies to firmware version 4.00

Dear user,

We have made every effort to ensure the accuracy of the contents of this manual. Should any errors be detected, we would greatly appreciate to receive suggestions to improve the quality of the contents of this manual.

For more detailed technical data about Beamex MC6-T Multifunction Temperature Calibrator and Communicator, please contact the manufacturer.

© Beamex 2020

Beamex Oy Ab

Ristisuonraitti 10

FIN-68600 Pietarsaari

Finland

Tel:

+358-10-5505000

E-mail:

sales@beamex.com

service@beamex.com

Internet:

<https://www.beamex.com>

Table of Contents

Prologue.....	7
About This Manual.....	8
Where am I?.....	8
Typographical Conventions.....	9
Unpacking and Inspection.....	9
Feedback.....	10
MC6-T Safety.....	11
Approvals.....	11
Symbols Used.....	11
Operating Environment.....	11
Safety Precautions and Warnings.....	13
Warnings Concerning Temperature.....	14
Using the Temperature Block.....	14
After using the Temperature Block.....	15
Warnings Concerning Electrical Measurement and Generation.....	16
Warnings Concerning Pressure.....	16
General Warnings Concerning Pressure Measurement.....	16
Warnings Concerning High Pressure.....	17
General description.....	19
About MC6-T.....	19
Hardware.....	19
General.....	19
MC6-T top view.....	21
Connectors on the Left Side of MC6-T.....	22
MC6-T Handle.....	22
Memory.....	23
Display.....	23
Batteries.....	23
Power Management.....	24
User interface.....	28
PC Communication/Calibration software.....	32
USB Communication Driver.....	32
MC6-T Related Tools Available for Personal Computer.....	32
Options.....	33
Software Options.....	33
Hardware Modules/Options and Accessories.....	34
Accessory Holder Kit.....	34
Related Products.....	37

Active Terminals and Connections.....	39
General.....	39
Measurements.....	40
Temperature Measurement (Thermocouple).....	40
Temperature Measurement (RTD).....	41
Resistance Measurement.....	42
Pressure Measurement.....	43
Connecting and Disconnecting External Pressure Modules.....	43
Zeroing a Pressure Module.....	44
Current Measurement.....	44
Voltage Measurement.....	45
Frequency Measurement.....	45
Pulse Counting.....	46
Switch Sensing.....	47
Generations/Simulations.....	47
Changing the Generated/Simulated Value.....	47
Using the Soft Numeric Keypad.....	47
Spinning.....	48
Temperature Generation.....	49
Inserts to be used in the Temperature Block.....	50
Thermocouple Simulation.....	51
RTD Sensor Simulation.....	52
Current Generation (Source or Sink).....	53
Voltage Generation.....	54
Resistance Simulation.....	54
Frequency Generation.....	55
Pulse Generation.....	56
Thermocouple Connections.....	57
 Tools.....	 59
Tools for Measurements.....	60
Additional Stability Check.....	62
Tools for Generations/Simulations.....	64
 Temperature Calibrator.....	 67
About Temperature Calibrator.....	67
The Menu.....	70
 Calibrator.....	 71
About Calibrator.....	71
 Documenting Calibrator.....	 73
General.....	73
Calibration Software.....	74
Calibrating Instruments.....	74

Generating/Simulating the Input Value.....	75
Instrument List.....	75
Instruments.....	76
Instrument List Window Menu.....	87
Plant Structure Levels.....	88
Work Order View Mode.....	88
Instrument Overview Window.....	90
Calibrating an Instrument Using MC6-T.....	91
Changing the Pressure Module During Calibration.....	95
About Fieldbus and HART Device Specifics.....	96
Calibration Results.....	97
Deleting Calibration Results.....	98
Get mapped value feature.....	98
Getting and Editing Mapped Data.....	99
Preparations.....	99
Getting Default Mappings.....	100
Customizing the Mappings.....	100
Mobile Security Plus software option.....	103
General.....	103
Applied Restrictions.....	103
Data Logger.....	105
General.....	105
Doing a Data Log.....	106
Configuring.....	106
Saving and Opening Configurations.....	109
Starting the Data Log.....	110
Viewing and Saving or Deleting the Results.....	111
Viewing Saved Data Log Results.....	112
Transferring Data Log Results to a Personal Computer.....	113
Communicator.....	115
General.....	115
Warnings.....	118
Connections.....	118
Selecting the Instrument.....	120
List of Found Devices.....	121
About Instrument Parameters.....	122
Instrument Parameters in General.....	122
Calibrating or Data Logging HART Instruments.....	123
Calibrating or Data Logging Fieldbus Instruments.....	124
Editing Parameters.....	125
Trimming a HART Instrument.....	126
Trimming a Fieldbus Instrument.....	129
HART Device Description Specifics.....	131
About HART Device Description.....	131
Basic View.....	132
Managing Digital Communication Instrument Configurations.....	134
General.....	134

Tools in MC6-T.....	135
Saving Configurations.....	135
Viewing/Managing Configurations.....	135
Beamex MC6 Fieldbus Configuration Viewer.....	136
Uploading Configurations.....	137
Linking Configurations to CMX.....	137
Settings.....	139
Settings overview.....	139
Maintenance.....	141
Replacing the mains fuses.....	141
Overtemperature Protection Test Mode.....	142
Cleaning instructions.....	143
Firmware Update.....	144
Recalibrating MC6-T.....	144
Disposal of Waste Electrical and Electronic Equipment.....	145
Beamex and WEEE.....	145
Service and transportation instructions.....	147
Safe delivery for service.....	147
Resetting MC6-T.....	149
Additional Information.....	151
User Defined Function Data.....	151
User Defined PRT/RTD Sensors.....	152
General.....	152
Callendar van Dusen Formula for PRTs.....	154
ITS-90 PRT Sensor.....	155
Factor.....	157
Check Sensor Conversion.....	158
User Defined Transfer Functions.....	159
User Defined Pressure Units.....	161
User Defined Steps Calibration Points.....	163
Controller Communication.....	164
What Can be Done With Controller Communication....	165
Configuring Controller Communication.....	166
Changing Controller During Calibration.....	167
Index.....	169

Prologue

Thank you for buying Multifunction Temperature Calibrator and Communicator.

Beamex MC6-T is an advanced, high-accuracy field calibrator and communicator. It offers calibration capabilities for temperature, various electrical signals as well as pressure. MC6-T also contains a fieldbus communicator for HART, FOUNDATION Fieldbus and Profibus PA instruments.

MC6-T consists of two main parts: Temperature Block and Process Calibrator. MC6-T is equipped with an internal battery, therefore the Process Calibrator functions can be used without mains voltage.

There are two different models available for MC6-T:

- MC6-T150 that can generate temperatures between -30..150 °C, at ambient temperature of 23 °C.
- MC6-T660 that can generate temperatures between 50..660 °C.

This manual is valid for both models.

MC6-T's main features are multifunctionality and ease-of-use. MC6-T is one device with five different operational modes: Temperature Calibrator, Calibrator, Documenting Calibrator, Data Logger and Communicator. In addition, MC6-T communicates with Beamex CMX and LOGiCAL calibration softwares, enabling fully automated and paperless calibration and documentation. MC6-T can also communicate with external temperature and pressure controllers/generators.

About This Manual

MC6-T User Manual is divided into several parts as follows:

- **Prologue**, contains a general presentation of MC6-T.
- **MC6-T Safety**, includes safety warnings and precautions.
- **General description** discusses general matters.
- **Active Terminals and Connections**. Whatever you measure, generate or simulate, here's how to make the necessary connections.
- **Tools**, presents the tools available in MC6-T.
- **Temperature Calibrator**, an operational mode for using the Temperature Block to manually calibrate up to three temperature probes or instruments simultaneously.
- **Calibrator**. A more generic operational mode which allows you to measure/generate/simulate two things at the same time etc.
- **Documenting Calibrator** concentrates on instrument calibration using the full featured documenting calibrator.
- **Data Logger**. Collecting and reviewing data and transferring logged data to a PC.
- **Communicator**. Invoking digital communication with modern instruments. This feature is optional.
- **Settings**. How to customize MC6-T and what the **About** window contains.
- **Maintenance**. Contains a description of maintenance actions available to the user.
- **Service and transportation instructions**. Useful information about how to send the device for service.
- **Additional Information**. About advanced tools for, e.g. adding custom pressure units, connecting external devices etc.

Where am I?

The header of each page in MC6-T User Manual informs you of where you are: The even page shows the part you are in and the odd page shows the main topic you are currently viewing.

Example of even page header:

2 – Part 1, Introduction

Example of odd page header:

About This Manual – 3

Typographical Conventions

The following typographical conventions apply to the MC6-T User Manual:

Bold text is used in following situations:

- References to User Manual topics and parts,
- MC6-T keywords, i.e. terms shown in the User Interface and
- other keywords, e.g. the names of fieldbus parameters.



Note: This is a note. Notes typically inform you of something useful concerning the current topic.



CAUTION: This is a caution. Whenever you see a caution, read it carefully and take it seriously. By not observing cautions, you may damage the calibrator.



Warning: This is a warning. Whenever you see a warning, read it carefully and take it seriously. By not observing warnings, you may -at worst- damage the calibrator and/or even risk your life.

Unpacking and Inspection

At the factory each new MC6-T passes a careful inspection. It should be free of scrapes and scratches and in proper operation order upon receipt. The receiver should, however, inspect the unit for any damage that may have occurred during transportation. If there are signs of obvious mechanical damage, package contents are incomplete, or MC6-T does not operate according to specifications, contact the purchasing sales office as soon as possible.

If you have to return the device to the factory for any reason, use the original packing whenever possible. Include a detailed description of the reason for the return. Read also chapter [Service and transportation instructions](#), section **Safe delivery for service**.

For a description of available options, see [Options](#).

Standard accessories:

- Accredited calibration certificate,
- this User Manual,
- Warranty Card,
- insert removal tool,
- Mains cord specific to your regions mains electricity,
- Cu/Cu extension cable,
- test leads,
- clips as follows:
 - a pair of Grabber clips and
 - two pairs of Alligator clips,
- USB cable,
- "Stay up to date" card, which contains links to Beamex website, where different software tools (e.g. remote controller) can be downloaded from,

Feedback

We want to improve our products and services constantly. Therefore we'd like to know Your opinion of the product You use. Please spend a moment of Your valuable time by giving us feedback about the product.

Address:	Beamex Oy Ab
	Quality Feedback
	Ristisuonraitti 10
	FIN-68600 Pietarsaari
	FINLAND

E-mail:	support@beamex.com
---------	--

Internet:	https://www.beamex.com
-----------	---



MC6-T Safety

Approvals

Safety	Directive 2014/35/EU	IEC 61010-1:2010
		IEC 61010-2-010:2014
		IEC 61010-2-030:2010
EMC	Directive 2014/30/EU	EN 61326-1:2013

Symbols Used

The following symbols concerning safety are used on the MC6-T.

	Caution! See manual for further information
	Caution! Hot surface

Operating Environment

	<p>Warning: Only use the calibrator for purposes and in environments specified in the user manual.</p> <ul style="list-style-type: none"> • Do not use in wet conditions. • Do not use in pollutive environments. • Do not use in potentially explosive environments.
---	---

Operating Temperature	0 ... 45 °C (32 ... 113 °F)
Storage Temperature	-20 ... 60 °C (-4 ... 140 °F)
Operating Humidity	0 to 90 % R.H. non condensing
Storage Humidity	10 to 60 % R.H. non condensing
Max. safe operating altitude	5000 m (approx. 16404 ft)
Pollution Degree	2 (only non-conductive POLLUTION occurs except that occasionally a temporary conductivity caused by condensation is expected)

Indoor use only



Note: Beamex provided temperature specifications are valid for ambient temperatures between 13..33 °C. Outside of this scope, temperature coefficients must be used. For more information about temperature coefficients see *User Guide for Beamex CMX Calibration Software*.



Note: MC6-T150's heating/cooling modules undergo normal aging process during usage, after which minimum reachable calibration temperature may be higher.



Note: Using the calibrator in a highly pollutive environment, such as coal mine and steel factory is not allowed, unless the calibrator is stored and used in a non-pollutive area, for example a dedicated calibration room that has suitable air filters. Contamination of conductive dust can cause electrical hazard.



Note: If the calibrator has been stored in different environment, it should be allowed to stabilize to new environment before use.

For all measurement ports except IN and OUT a cable not longer than 3 m must be used.

Sometimes it is necessary to use a portable radio transceiver while working with the calibrator. To prevent calibration errors caused by the radio frequency interference, keep the radio far (at least 1 meter) from the calibrator and the circuit under calibration while sending.

Safety Precautions and Warnings



CAUTION: Read and fully understand this manual and all other safety instructions before operating this Multifunction Temperature Calibrator and Communicator.



CAUTION: Only qualified and trained personnel is allowed to use the **MC6-T**.

Working with MC6-T involves the usage of temperature, electrical and pressure instruments. Only personnel with good experience and knowledge of high temperature media, high temperature instruments and connections are allowed to work with the **Temperature Block**. Incorrect use may result in damage to the device and/or personal injury.



Warning: Do not use MC6-T in any other way than as described in this User Manual. If this equipment is used in a manner not specified by the manufacturer, the protection provided by it against hazards may be impaired.



Warning: To ensure safe use of the MC6-T follow these rules:

- Mains cord of correct type and rating must be used. The Mains cord of the calibrator is equipped with a grounding plug for your protection against electrical shock hazards. It must be plugged directly into a properly grounded receptacle.
- Always make sure that mains inlet socket is easy to reach in case the Mains cord needs to be unplugged. It is located at the front of the device for maximizing safety.
- The device must always be used in upright standing position.
- Free space must be ensured around the calibrator. 25 cm is required on all sides and 1 m above the calibrator to allow correct ventilation.



Warning: Use MC6-T only if you are certain of that it can be used safely. Safe use of MC6-T is no longer possible if one or more of the following cases are true:

- When the enclosure of MC6-T is evidently damaged
- When MC6-T is not functioning as expected
- When there is unusual smell emitted by the battery of the device
- After prolonged storage in unfavorable conditions
- After serious damage during transport

Warnings Concerning Temperature

Using the Temperature Block



Warning: The MC6-T is a temperature calibrator which has been designed for calibrating instruments with typical industrial calibration procedures. It has not been designed for prolonged use at a temperature setpoint. Very low and very high temperatures may cause injuries if touched. Temperatures below dew point may cause condensation on cold surfaces in high humidity environments. If water gathers on top of the device, wipe the excess liquid away with a clean cloth. Do not leave the calibrator unattended. Always power off the calibrator when not using it.



Warning: The areas marked with hot surface warning symbol  might be hot during usage of the calibrator and must not be touched. Never leave the calibrator unattended while it is hot.

The hot warning symbol next to the screen will light up to indicate when the Temperature Block is hot.



Warning: A removable insert must not be removed from or inserted to the Temperature Block when block temperature is above 50 °C. Do not touch the insert when it is hot. Note that the instruments to be calibrated may also be hot and must not be touched during calibration.



Note: Use sensor heat shield when calibrating sensors at temperatures above 150 °C to protect the handle and internal structures of the sensor.



Warning: Any heat-transfer media, such as oil or paste, must not be used with a dryblock calibrator. Make sure that the Temperature Block boring is clean. If necessary, use a soft wipe or compressed air to clean it.



Warning: Avoid handling flammable objects or liquids near the calibrator as they might catch fire.



Warning: MC6-T's handle must be in down position during calibration to prevent it from getting too hot.

After using the Temperature Block



Warning: If the Temperature Block has been heated up to temperatures above 50 °C, it must be cooled down below this temperature before switching off the device.



Warning: If the Temperature Block has been cooled down to temperatures below dew point, it must be heated up until all water has evaporated from the Temperature Block and insert. Temperature Block must then be cooled down below 50 °C before switching off the device.



Warning: Always remove the insert from the Temperature Block when not using the calibrator. Use the insert removal tool for removing the insert.



Warning: Always switch off the Mains switch when not using the device.



Warning: Never set the device inside a carry case if the Temperature Block temperature is above 50 °C or below dew point.

Warnings Concerning Electrical Measurement and Generation



Warning: MC6-T's OUT section terminals are protected against over voltage and over current as far as it has been possible without affecting the accuracy. Do not however connect signals that are above the measurement range of the selected Function.

Maximum output voltage from MC6-T's terminals is below 30 V. If you, however, connect together voltages from the IN and OUT sections or if you connect external voltages to MC6-T, the resulting voltage may be high enough to be hazardous.

There is no galvanic isolation between the USB, Ethernet and External Pressure Module connectors.

However there is a galvanic isolation between MC6-T's IN and OUT sections. R3 connector is also galvanically isolated from the other connectors. It is for functional purposes only. Do not exceed 60 VDC / 30 VAC / 100 mA between any terminals.

Functional isolation is not intended for protection against transient overvoltages. Do not connect measuring terminals to circuits where transient overvoltages are possible.

Warnings Concerning Pressure

General Warnings Concerning Pressure Measurement



Warning: The maximum pressures of optional pressure T-hoses may not be exceeded.

Applying higher pressure than the maximum pressure can be hazardous.

We recommend the use of the optional pressure hose sets. When using other hoses and connectors, make sure they are high quality products that withstand the used pressure.

**Warning:**

Always depressurize the system before opening or connecting any pressure fittings or connectors. Use proper valves for venting the system. Ensure that all connections are made correctly and that the hose and the connectors are intact.

External pressure modules have the allowed media printed on the module's sticker. Using unsuitable pressure media may destroy the pressure module/calibrator.



Warning: External Pressure Modules: Use only the pressure media stated on the pressure module. Use of wrong type of Pressure Media may destroy the pressure module.

Never exceed the maximum pressure of a pressure module. The maximum pressure of external modules is stated on module's sticker and mentioned in the Instruction Booklet that is provided with the external module.

Never plug a hose with your hands or put hands in front of a gas spray coming from a leakage. A gas bubble in the blood circulation can cause death.

Warnings Concerning High Pressure



Warning: High pressure is always dangerous. Only personnel with good experience and knowledge of high pressure liquid, air and nitrogen operations are allowed to work with the module. Read carefully all these instructions and familiarize yourself with local safety instructions for high pressure operations before starting the use.

When using gas, the system must not contain any liquid, especially if you do not know how they may react under pressure. Use of clean air or nitrogen is recommended as gaseous pressure media. Liquid pressure media should be preferred when using modules with a pressure range of 60 bar (30000 psi) or more.



Warning: If you use nitrogen, minimize the leak to the atmosphere and take care of sufficient ventilation. Close the valve of the nitrogen cylinder, when the system is not in use. Increase in the percentage of nitrogen in the ambient air may cause unconsciousness and death without warning. Read carefully the safety instructions for nitrogen and make sure that other people in the same space are aware of the danger.

Use of liquid pressure medium is recommended with pressure measurement modules at higher pressure range. Use water or suitable hydraulic oil. Check that the used liquid is not aggressive against the materials used in the transducer or tubing. When using liquid, minimize the amount of air in the system to minimize the amount of spilled liquid in case of leakage.



Warning: Do not use the same tubing with different liquids or gases.

Check what the local regulations say about construction and use of pressurized vessels. The regulations normally control construction and use of systems where the product of the pressure and volume exceeds a certain limit. The volume of this system depends on the instrument connected to it.

High pressure gas is dangerous because it can break the container and the flying splinters may cause injury. Also small leaks of gas may be dangerous because the high velocity of the leaking gas jet enables penetration through skin. If a gas bubble gets into the blood circulation, it can cause death. The leak jet is particularly penetrative, if some liquid is coming with the gas.

General description

Things discussed in this part:

- Briefly about MC6-T's hardware and firmware
- Available software and hardware options
- Power management explanation

About MC6-T

Hardware

General

Figure 1: MC6-T, overview presents a general view of the MC6-T, its parts and its buttons' functionality.

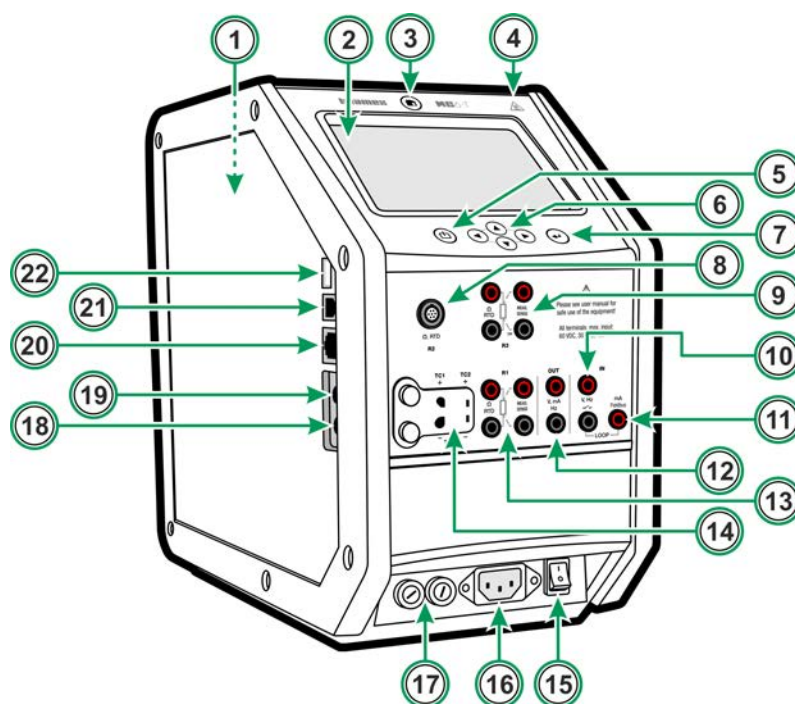

Figure 1: MC6-T, overview

Legend:

1. **Temperature Block**. See also [Figure 3: MC6-T, top view](#).
2. **Display and Touch Panel**.
3. **Home** button. Press this button to return to **Home View**.
4. **Hot Temperature** warning symbol that lights up when the Temperature Block is hot.
5. Process Calibrator **Power** button, see chapter [Power Management](#).
6. **Arrow** buttons. First press displays the **Hardware Focus Indicator**. Further presses move the indicator on the Display.
7. **Enter** button for selecting the item surrounded with the **Hardware Focus Indicator**.
8. **RTD and Resistor** connector (**R2**).
9. **RTD and Resistor** connector (**R3**).
10. **Voltage, Frequency and Switch** input (**IN**).
11. **Current Measurement, Loop Supply, HART[®] and Fieldbus** connection (**IN**).
12. **Voltage, Current and Frequency** output (**OUT**).
13. **RTD and Resistor** connector (**R1**).
14. **Thermocouple** connectors (**TC1** and **TC2**). TC1 for cables and standard TC plugs and TC2 for TC plugs with flat contacts.
15. **Mains switch** (115 V / 230 V). For more details see [Power Management](#).
16. **Mains Inlet socket** (115 V / 230 V) to connect the Mains cord.
17. **Fuse** holders.
18. **External Pressure Module connector**.
19. **Internal Barometric Pressure Module** (optional).
20. **Ethernet** connector.
21. **USB-B** connector.
22. **USB-A** connector.

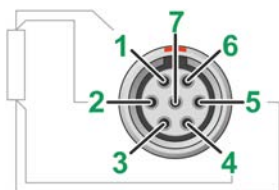

Figure 2: Outside view of the female connector in MC6-T

R2 connector's pin order:

1. Excitation current +
2. Sense +
3. Not in use
4. Sense -
5. Excitation current -
6. Not in use
7. Not in use

MC6-T top view

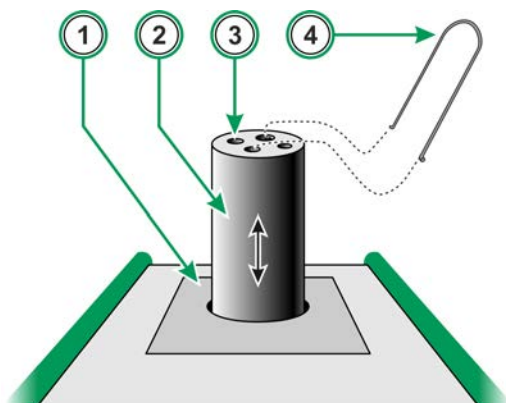

Figure 3: MC6-T, top view

Legend:

1. **Temperature Block**
2. **Replaceable Insert** (not included in the standard delivery)
3. Insert **Boring**
4. **Insert removal tool**



Note: Replaceable inserts with different sized borings must be used within the Temperature Block to allow calibration of temperature probes and instruments with different diameters. See also [Hardware Modules/Options and Accessories](#). Contact Beamex for available insert types.

Connectors on the Left Side of MC6-T

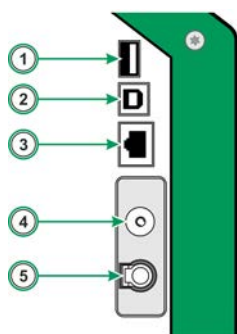

Figure 4: Connectors on the left side of MC6-T

Legend:

1. **USB-A** connector for connecting USB devices to MC6-T. See also chapter [Firmware Update](#).
2. **USB-B** connector for communicating with a Personal Computer. For details see chapter [PC Communication/Calibration Software](#).
3. **Ethernet** connector for connecting MC6-T to a Local Area Network. This connector is used for Beamex internal purposes only.
4. The optional **Internal Barometric Pressure Module**. It has a venting hole on the side of MC6-T. To ensure valid barometric pressure measurements, do not plug the venting hole.
5. **PX**. A possibility to connect Beamex External Pressure Modules to MC6-T.



Note: All USB connectors are USB 2.0 Full Speed ports.

MC6-T Handle

The MC6-T's handle is designed to have three positions:

- **Carrying** – when the handle is gripped and device is being carried, handle is in a position where it is very close to the center of mass of the device and the calibrator is comfortable to carry;
- **Resting** – when the handle is released, it falls down to a resting position where it is easy to grip again;
- **Down** – when the handle is pushed down, its top surface is aligned with the top surface of the device. Use this position during calibration and transportation.



Warning: The handle must always be pushed to Down position during the calibration. The resting position is designed to ensure that it is not possible to leave the handle in carrying position, in which case it would get very hot during calibration at highest temperatures.

Memory

MC6-T maintains data very much like personal computers. Data is saved on a solid state memory that does not need any power to maintain its state. Solid state memory is shock-proof so that data is not lost when the calibrator is transported. Also, you can safely save a large amount of instruments, calibration results and data log results.

Available memory can be used for anything that requires it (e.g. instrument data, calibration results, etc.).

Display

MC6-T has a backlit 640 × 480 pixel 5.7" TFT Display and Touch Panel. Use the touch screen with your fingers, gloves on or off. Optionally, use a stylus meant for touch screen use.

See also brightness settings in [Settings](#).



Warning: Do not tap the touch screen with sharp or hard objects or press hard on the display, especially with fingernails. Instead, tap lightly using your fingertips. Using sharp tools such as a screwdriver on the touch screen may damage it.

Batteries

MC6-T has internal rechargeable Lithium Polymer (LiPo) battery. Since LiPo batteries do not suffer from the memory effect, they may be charged at any time. The internal battery is maintained and charged with a built-in intelligent charger always when MC6-T is connected to mains voltage and Mains Switch is on. No separate charger is provided.

The maximum operating time of the batteries without recharging varies, especially depending on the usage of the display back light. The usage of the 24 V transmitter supply also affects the maximum operating time. Even with constant maximum load, the standard rechargeable batteries should last for 10 hours. A good average operating time is 16 hours.



Figure 5: Full battery - empty battery



Note: A time estimate (hh:mm) is shown on the battery symbol. During charging it is the charging time left, otherwise it is remaining usage time.



Note: When MC6-T is not used for a longer period, charge MC6-T in 3 month periods. MC6-T's internal clock/calendar uses a small amount of current even when the calibrator is switched off. Remember to check the capacity of the batteries from time to time even though MC6-T is not in use. Power it on if a recharge is needed. Tap the battery icon to open a window displaying detailed battery/charging information.

Power Management

MC6-T is equipped with two power buttons:

- Mains switch - powers on all functions of MC6-T, both Temperature Block and Process Calibrator



- Calibrator Power button - powers on Process Calibrator even when MC6-T is not connected to mains voltage



Note: In Process Calibrator state electrical and pressure functions are enabled but Temperature Block is disabled. Using the Temperature Block is only possible when MC6-T is connected to mains voltage. R3 terminal is a part of the Temperature Block and it is not enabled in Process Calibrator state.

For powering off, use the same power button you used to power on. Switching off the Mains switch disables all functions, with a few exceptions.



Warning: If the Temperature Block has been heated up to temperatures above 50 °C, it must be cooled down below this temperature before switching off the device.



Warning: Always switch off the Mains switch when not using the device.

Temperature Block must always be cooled down below 50 °C before switching off the Mains switch. When switching off the Mains switch, MC6-T will be set to Standby mode, allowing faster startup if the Calibrator Power button is pressed again.

If the Temperature Block is not cooled down before Mains switch is switched off, MC6-T will go to Temperature Warning mode and not allow

powering off. You will be prompted to turn the Mains switch back on to allow the Temperature Block to cool down faster. When you turn the Mains switch on, cooling will automatically start in a silent mode. Set temperature setpoint close to ambient to minimize cooling time. If you fail to switch the Mains switch back on, the MC6-T will go to the Standby mode after it is safe.

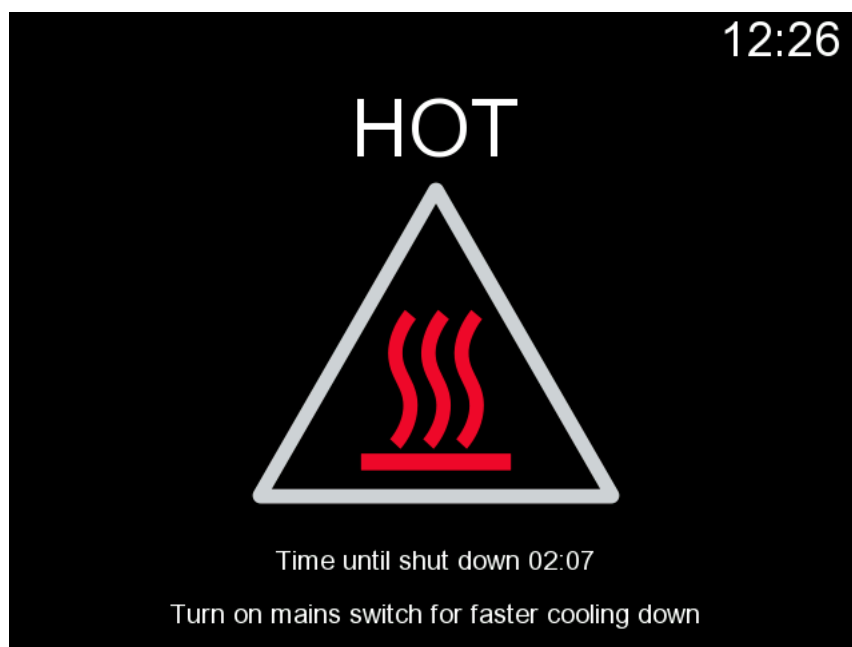

Figure 6: Temperature Warning mode

If the calibrator is in use when the Mains switch is switched off, Process Calibrator will stay on and, if possible, continue with the operation it was occupied with. Process Calibrator needs to be powered off from the Calibrator Power button once it is no longer in use.



Note: Calibrator is in use in the following cases:

- when adjusting MC6-T's own measurement/generation/simulation ranges,
- when a data log is in progress
- when an instrument calibration is in progress in Documenting Calibrator.

Pressing the Calibrator Power button when MC6-T is on opens a Power Menu dialog with following options:

- **Calibrator Power Off** to shut down Process Calibrator, i.e. minimum battery power and full startup procedure;
- **Standby** to set the Process Calibrator in Standby Mode, allowing faster startup when the Calibrator Power button is pressed again;
- **Backlight Off** to temporarily set the backlight off.



Note: When Mains switch is on, Calibrator Power Off and Standby are not active due to safety reasons. Power off MC6-T from the Mains switch.

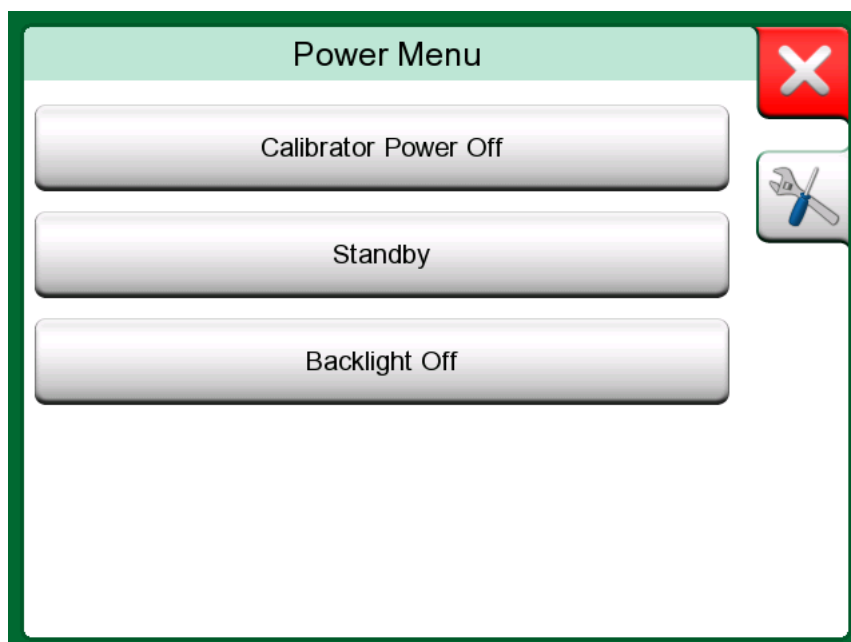

Figure 7: Power Menu dialog

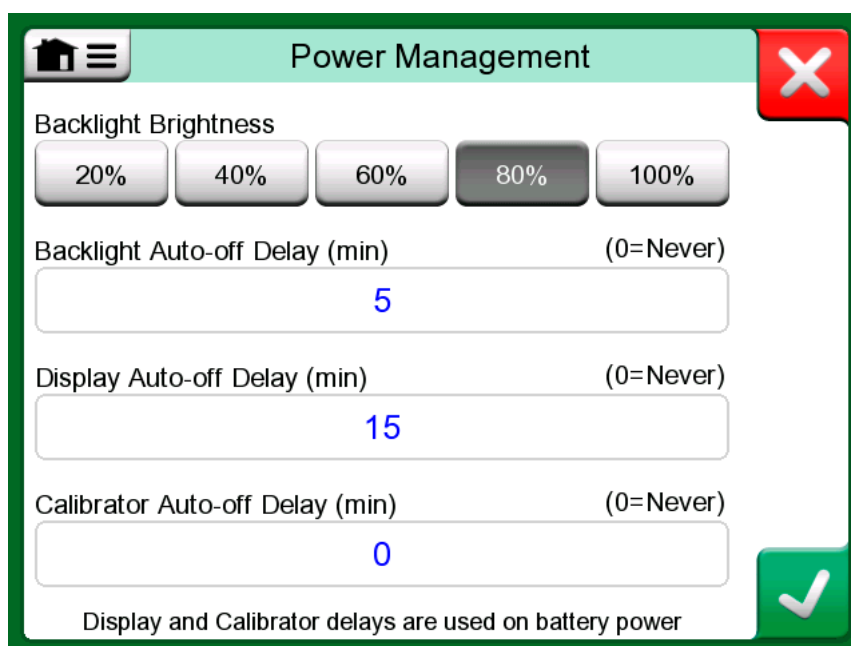

Figure 8: Power Management window

Pressing Tools button in Power Menu will take you to Power Management window (see [Figure 8: Power Management window](#)). Adjust the Backlight Brightness and set the delays for backlight, display and calibrator Auto-off to save battery.



Note: Auto-off is not active when calibrator is in use.

The startup procedure ends in **Home View**. From MC6-T's **Home View** you may advance to any of the available main operational modes. This manual contains detailed information about main operational modes as follows:

- **Temperature Calibrator**,
- **Calibrator**,
- **Documenting Calibrator**,
- **Data Logger**,
- **Communicator** and
- **Settings**.

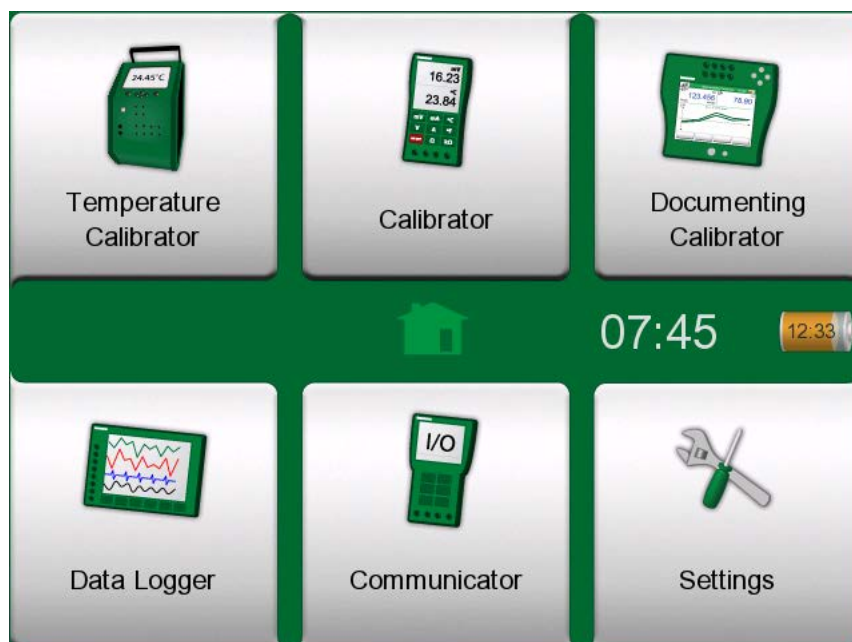

Figure 9: Home view



Figure 10: Power button (left) and Home button (right)

With the **Home** button you can always return to **Home View** from wherever you are.

User interface

You can interact with MC6-T by tapping on available buttons/controls displayed on the touch screen. Optionally: use the hardware arrow keys to move between the available buttons/controls. The first time you push a hardware arrow key the **Hardware Focus Indicator** is displayed (a blue border around the active button/control). When using the hardware arrow keys, use the hardware Enter key to select ("tap") a button/control.

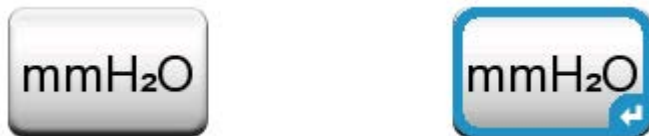

Figure 11: Button without and with a Hardware Focus Indicator

Buttons often open a pop-up window for entering data, e.g. a unit button with the text "mmH₂O" opens a pop-up window of available units. Certain buttons do have special functionality, like "**Accept**" and "**Close**" buttons. They close a pop-up window and either accept or reject the changes. There are other buttons, e.g. for going to the next/previous page pages, scrolling through a wide table of data, removing a number in a numeric field (backspace), clearing a numeric field, etc. Most of them are familiar since they look similar as in personal computer software.



Figure 12: Accept button (left) and Close button (right)

One important button is the **Menu** button which is available in the upper left corner of almost any window. Tap on it to open a context-sensitive menu with a software version of the Home button.



Figure 13: Menu button (on the left)

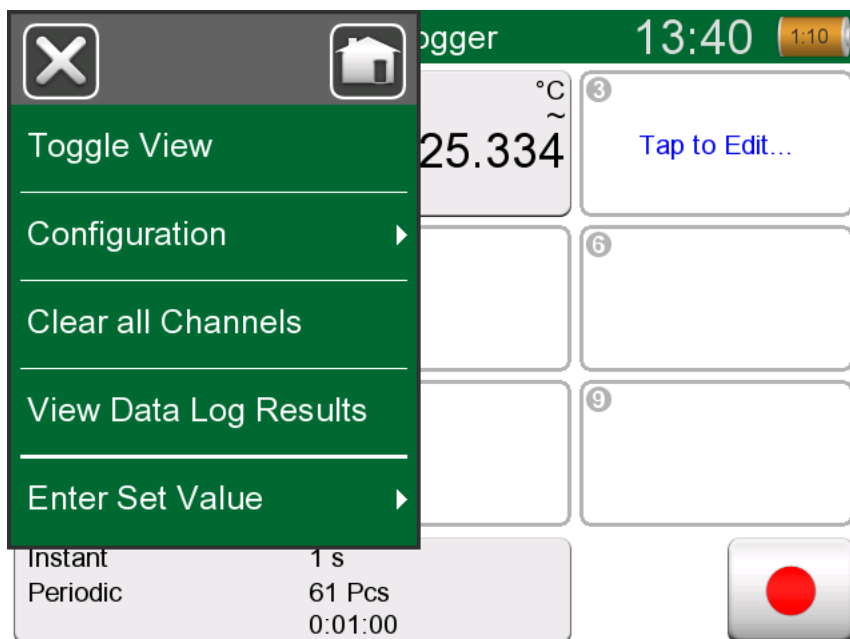

Figure 14: An example of an opened menu

Check Boxes are special buttons that are either "checked" or "unchecked". See [Figure 15: Check Boxes, both a checked and an unchecked one](#). Again, the functionality is familiar from Personal Computers.



Figure 15: Check Boxes, both a checked and an unchecked one

MC6-T also has some "flat" buttons. They are used in, e.g. lists. The color of the flat buttons may vary depending on the context.

The following editable fields are available:

- **Text Fields,**
- **Numeric Fields,** in certain cases including **Spinning** and
- **Date/Time Fields.**

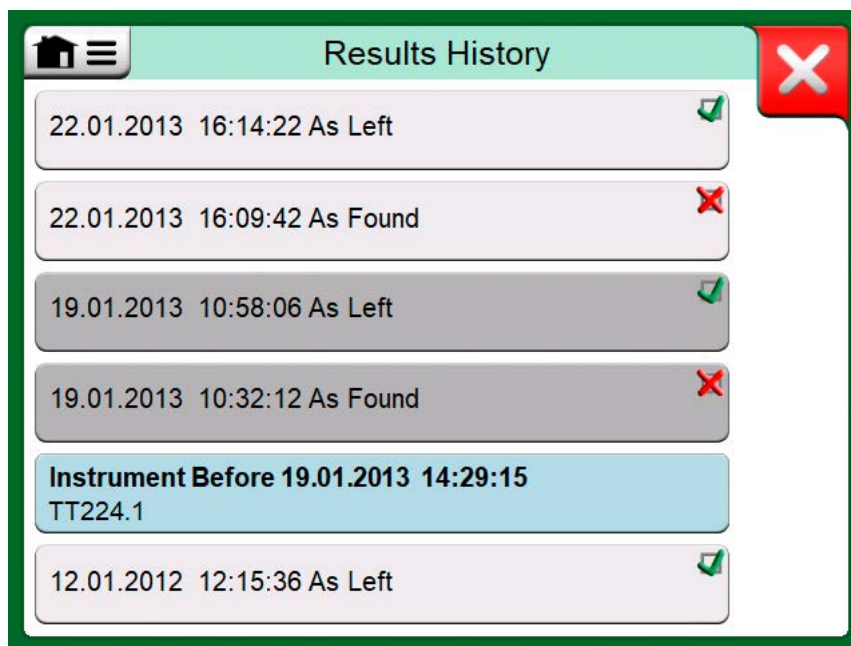

Figure 16: Example of a list with flat buttons

The letters/numbers on all editable fields are blue to indicate that they are editable. Black texts are descriptive user interface texts that are not editable. An example of a Text Field and the Text Edit Window are shown in [Figure 17: Text Field](#) and [Figure 18: Text Edit window](#).

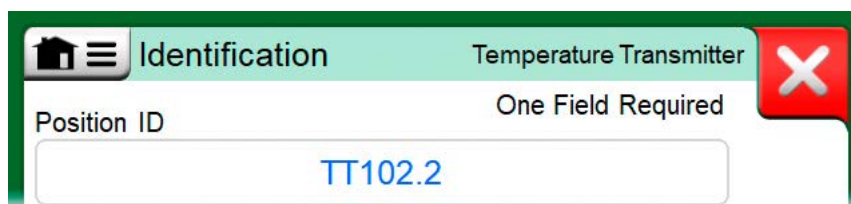

Figure 17: Text Field

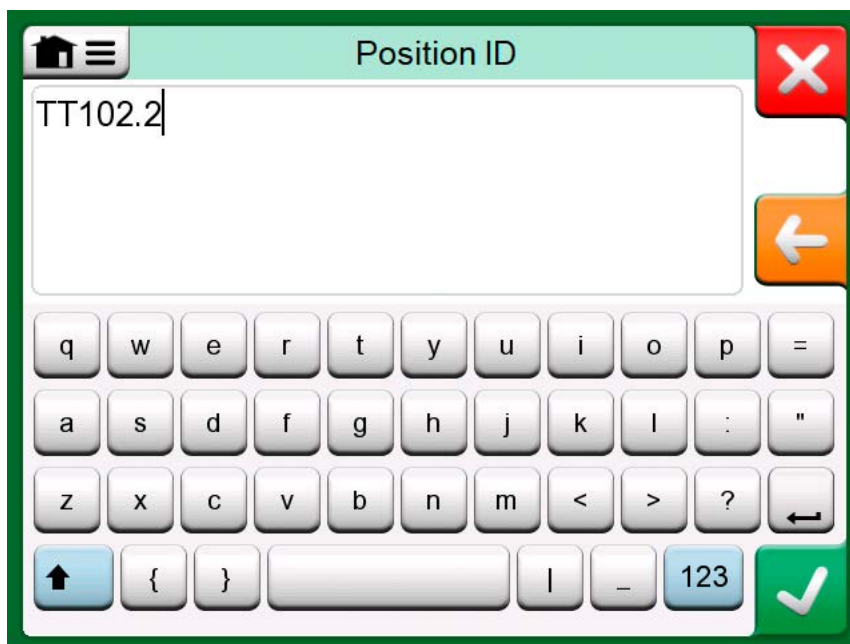

Figure 18: Text Edit window

Use of Numeric Fields and Spinning is described in [Active Terminals and Connections](#) and [Documenting Calibrator](#).

Date Fields are actually special cases of Numeric Fields. Entering the date is just like entering any numeric value.

Setting MC6-T's time is a special case of the Spinning functionality. The "Left" and "Right" arrow buttons move the highlight to another digit. The "Up" and "Down" arrow buttons change the value of the highlighted digit.

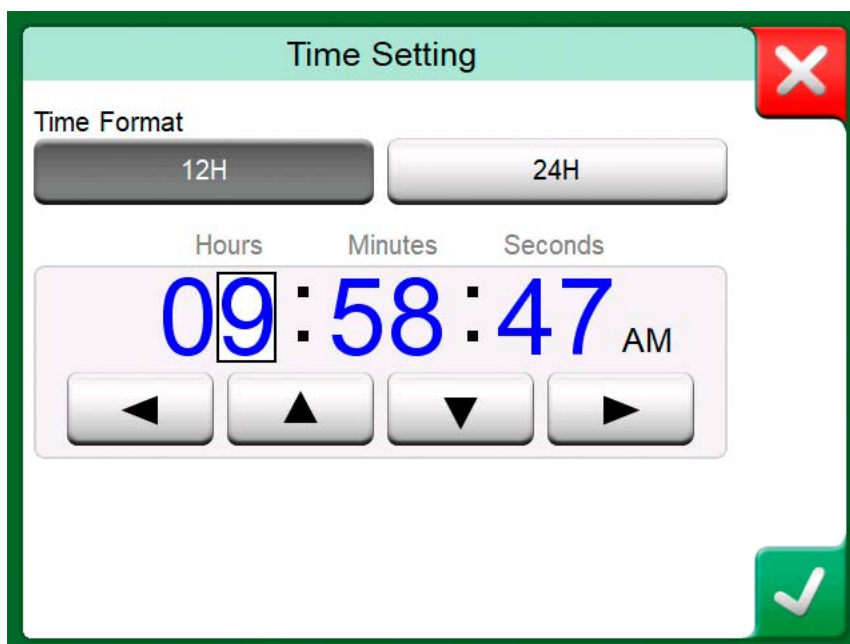

Figure 19: Time Setting window

PC Communication/Calibration software

Beamex CMX Calibration Software supports MC6-T from version V2, revision 2.12 onwards and also in **Beamex LOGiCAL**, version 2, a cloud based calibration management software.

USB Communication Driver

MC6-T uses Windows' generic USB driver (WinUSB) provided by Microsoft. Supported operating systems: Windows[®] 8 and newer.

MC6-T Related Tools Available for Personal Computer

The following tools are available for download at Beamex's web site: <https://www.beamex.com>. Look for **Download Center and Software tools for MC6 family**.

- **Beamex MC6 Data Log Viewer**, for transferring Data Log results to a PC and viewing them on the PC.
- **Beamex MC6 Device Description Installer**, for installing new Device Descriptions of smart transmitters from the PC to MC6-T.
- **Beamex MC6 Fieldbus Configuration Viewer**, for downloading smart transmitter configurations into the MC6-T and then to the PC.
- **Beamex MC6 Remote Controller**, for controlling MC6-T via the PC.

Options

Software Options

The following software options are available:

- **Mobile Security Plus**, a solution which ensures the integrity of calibration data throughout the Beamex ICS solution. This option is also required in **CMX Calibration Software**,
- Multi channel **Data Logger**,
- **Communicator**, HART[®],
- **Communicator**, FOUNDATION Fieldbus[™], ⁽¹⁾
- **Communicator**, PROFIBUS PA[™], ⁽¹⁾
- Drivers for **External Controllers** (Pressure and Temperature) ⁽²⁾ and
- **Special Temperature Sensors**.



Note: The software options activated in MC6-T can be found in MC6-T's **Settings** main function. Select **About** option and browse to page 3. Whether the communication hardware needed for fieldbus communication is installed or not, can be found in MC6-T's **Settings** main function. Select **About** option and see page 1.

⁽¹⁾ Requires that communicating hardware is installed into MC6-T. Please contact Beamex.

⁽²⁾ When necessary, a connection cable is shipped when the software option is bought.

Hardware Modules/Options and Accessories

- Communicating hardware for MC6-T's **Communicator** software options. See also [Software Options](#),
- **Adapter cables** for R2 connector,
- **Cable** for Pressure and Temperature Controllers,
- MC6-T **Accessory Holder Kit**, see chapter [Accessory Holder Kit](#),
- **Additional multihole inserts** for both models, also blanco inserts (MC6-T150 inserts come with 2 insert insulations),
- **Hard Carrying Case**,
- **Internal Barometric Pressure Module**,
- **Pressure Hose Sets** to be used together with external **Pressure Modules**.

Accessory Holder Kit

MC6-T offers an optional **Accessory Holder Kit**, available for both models, which allows to:

- comfortably transport the accessories in the field,
- store additional accessories,
- fold the Mains cord for extra safety and convenience.



Note: The **Accessory Holder Kit** for the MC6-T660 model is additionally equipped with a **Heat Shield** that can be used to protect the sensor from excess heat during high-temperature calibration.

Figure 20: [Accessory Holder Kit](#), fully equipped (MC6-T150 on the left, MC6-T660 on the right) presents **Accessory Holder Kit's** parts, common and specific for both MC6-T models.

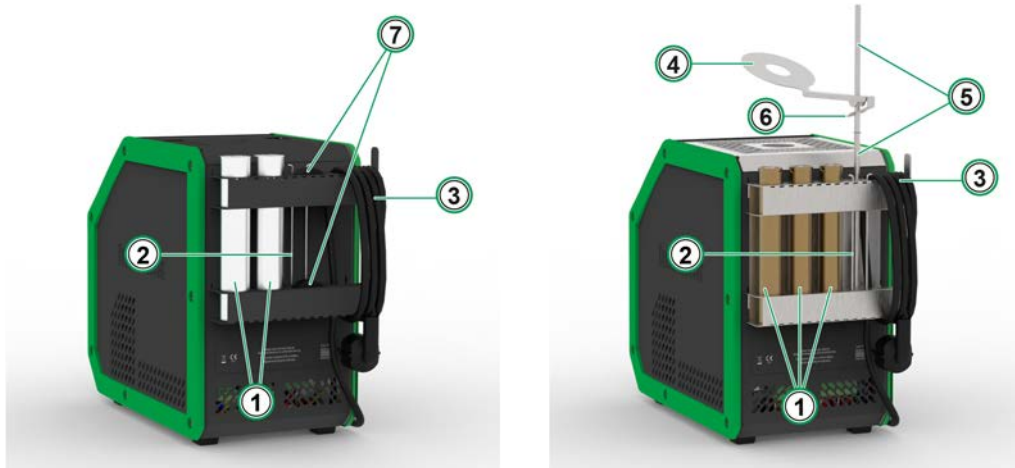

Figure 20: Accessory Holder Kit, fully equipped (MC6-T150 on the left, MC6-T660 on the right)

Legend:

1. **Cut-outs** designed to store additional inserts.
2. **Insert removal tool.**
3. Mains cord holder.
4. **Heat Shield.**
5. **Heat Shield Holder.**
6. **Heat Shield Tongue.**
7. **Cut-outs** for storing insert insulations (MC6-T150 model only).

Assembly

The **Accessory Holder Kit** delivered separately includes the tool needed for the assembly (Torx T20).

To assemble the **Accessory Holder Kit**, loosen two panel screws (**A** in [Figure 21: MC6-T660 Transportation position](#)). Slide the **Accessory Holder Kit** into place and tighten forementioned screws back. Follow the same steps in reverse order to detach the **Accessory Holder Kit** from the device.



Figure 21: MC6-T660 Transportation position

To install the **Heat Shield** (MC6-T660 model only), first connect the two parts of the **Heat Shield Holder** by twisting them together, then twist the whole **Heat Shield Holder** in place (there is a right side threaded hole in the bottom part of the **Accessory Holder Kit**). Slide the **Heat Shield** on top of the **Heat Shield Holder** by gently pressing the **Heat Shield Tongue** (6 in [Figure 20: Accessory Holder Kit, fully equipped \(MC6-T150 on the left, MC6-T660 on the right\)](#)). Adjust the **Heat Shield** position to achieve the desirable heat protection for your sensor.



Note: When moving around the factory, it is recommended to place the accessories into the **Transportation position**, as shown in [Figure 21: MC6-T660 Transportation position](#).

Related Products

There are an increasing number of devices that can be used together with MC6-T. The following list includes devices that are already available (valid when this manual was printed):

- Temperature sensors
 - Reference sensor RPRT-660 (straight and bent model),
 - Reference sensor RPRT-420 (straight and bent model),
 - Beamex IPRT-300 Pt100 probe, Industrial Platinum Resistance Thermometer,
 - Beamex SIRT-155 Pt100 probe, Short Industrial Resistance Thermometer.
- External Pressure Modules,
- Calibration hand pumps:
 - **PGV** vacuum pump,
 - **PGL** low pressure calibration pump,
 - **PGC** pressure/vacuum pump,
 - **PGM** high pressure pump,
 - **PGPH** high pressure pneumatic pump and
 - **PGXH** extra high pressure pump.
- Beamex **POC8** Automatic Pressure Controller,
- Beamex Field Temperature Block (**FB** Series),
- Beamex Metrology Temperature Block (**MB** Series),
- Beamex **CMX** Calibration Software and
- Beamex **LOGICAL**, version 2, a cloud based Calibration Management Software.

Active Terminals and Connections

Things discussed in this part:

- A presentation of measurements MC6-T is capable of performing. For all measurements, the active terminals together with useful additional information for that particular measurement are presented.
- Similarly, a presentation of generations and simulations MC6-T is capable of performing.
- For generations/simulations, there is also information on how to change the generated/simulated value.

General

This section of MC6-T User Manual presents all measurements and generations/simulations that MC6-T is capable of performing. No matter which of the available main functions you use in MC6-T, the connections presented here apply.

Settings in **Temperature Calibrator** or **Calibrator** are saved, so that the next time you measure, generate or simulate something, the previous settings are available as defaults.



Note: In the event of Mains switch being switched off, Temperature Block and R3 settings will not be available.

When you use **Documenting Calibrator** and select an instrument for calibration, the instrument's settings (**Quantity**, **Port** etc.) are inherited to the **Calibrator** subwindows (if the corresponding function is present and powered on).

Respectively, when creating a new instrument in **Documenting Calibrator**, the settings in **Calibrator**'s subwindows are used as default settings for the new instrument's input and output.



Note: For HART and Fieldbus instrument specifics, see [Communicator](#). For information on External Devices (Pressure and Temperature Controllers) used together with Calibrator and Documenting Calibrator, see [Additional Information](#).

In this manual, when presenting each function, there is a picture with highlighted active terminals. The highlight for possible optional connections is lighter. Connections to instruments are included if it requires special attention. See chapter [Current Generation \(Source or Sink\)](#).



Note: A measurement, generation or simulation in one subwindow reserve terminals in MC6-T. This may affect the availability of measurements, generations and simulations in the other subwindow. To free terminals, tap on the quantity button and in the opened window, tap on the **"Stop"** button.

Measurements

Temperature Measurement (Thermocouple)

MC6-T has two thermocouple connectors. **TC1** is for cables and standard TC plugs. **TC2** is for TC plugs with flat contacts.

Check the **Sensor Type**. Your measurement results are unreliable unless you select the same sensor type as is connected to MC6-T. Select also a suitable **Reference Junction** compensation method. Wrong settings yield useless measurement results. For more information see chapter [Thermocouple Connections](#).

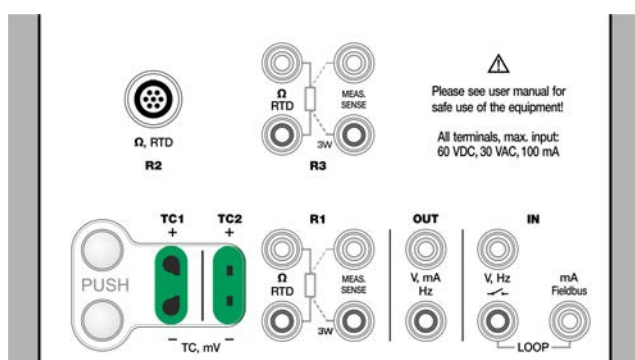

Figure 22: Thermocouple measurement terminals. Range depends on sensor type

See also chapters [Thermocouple Simulation](#) and [Voltage Measurement](#).



CAUTION: When using another thermocouple or an RTD sensor connected to MC6-T to measure the external reference junction temperature: Keep in mind that there is no galvanic isolation between the sensors.



Note: Thermocouple measurements are error prone. There may be faulty connections, wrong (extension) cables and settings in MC6-T. If unsure, see chapter [Thermocouple Connections](#) and study thermocouple literature.

Temperature Measurement (RTD)

Check the **Sensor Type**. Make sure you select the same sensor type as is connected to the MC6-T. Otherwise your measurement results are useless.

For R1 and R3 terminals:

The two leftmost terminals are used in 2-wire systems. MC6-T automatically checks the connection and displays the found wiring system (2-wire, 3-wire or 4-wire).



Note: For the 3-wire system measurements use the connector marked with "3W".

For R2 terminal:

R2 terminal always uses 4-wire measurement. See [Figure 2: Outside view of the female connector in MC6-T](#).

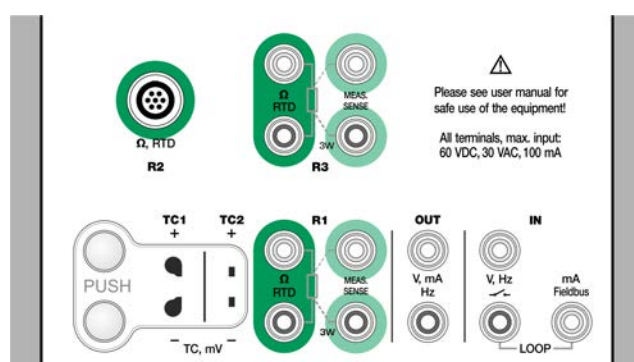

Figure 23: RTD measurement terminals. Range depends on sensor type

See also chapters [RTD Sensor Simulation](#), [Resistance Measurement](#) and [Resistance Simulation](#).



Note: To ensure good contact between the device under test and the test leads, we recommend using the alligator clips provided with MC6-T.

If you get "+OVER" or "-OVER" error messages, check the connections. If necessary, use 2-wire resistance measurement to check the wiring.

Resistance Measurement

For R1 and R3 terminals:

The two leftmost terminals are used in 2-wire systems. MC6-T automatically checks the connection and displays the wiring system found (2-wire, 3-wire or 4-wire).



Note: For the 3-wire system measurements use the connector marked with "3W".

R2 terminal always uses 4-wire measurement. See [Figure 2: Outside view of the female connector in MC6-T](#).

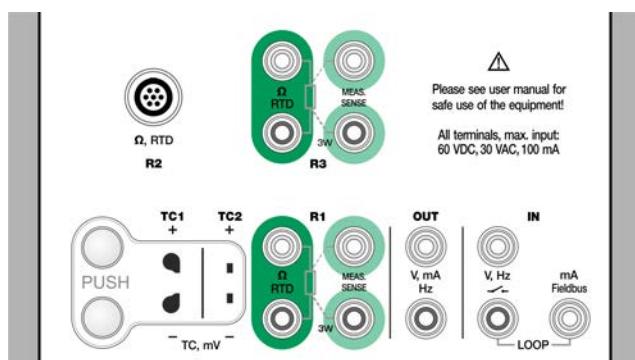

Figure 24: Resistance measurement terminals. Range -1 ... 4040 Ohm

See also [Resistance Simulation](#) and [Temperature Measurement \(RTD\)](#).



Note: To ensure good contact between the device under test and the test leads, we recommend using the alligator clips provided with MC6-T.

If you get "+OVER" or "-OVER" error messages, check the connections. If necessary, use 2-wire resistance measurement to check the wiring.

Pressure Measurement

MC6-T supports the use of external pressure modules, **EXT**, when they are connected to MC6-T's **PX** connector. MC6-T also includes an optional internal **Barometric Module** for measuring barometric pressure and together with a gauge EXT module, MC6-T indicates the absolute pressure of any pressure the EXT module is capable of measuring.

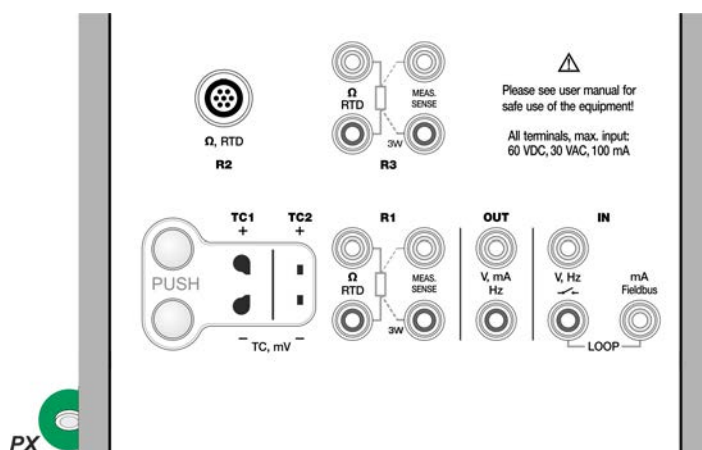

Figure 25: Connector for external pressure module's communication cable (PX).



Note: The pressure measurement requires knowledge of **pressure types** (absolute pressure, gauge pressure and differential pressure). Measuring pressure with inadequate knowledge of pressure types and the dangers of pressure devices may result in false measurement results and/or serious accidents. **Please read the warnings in chapter [MC6-T Safety](#).**

Connecting and Disconnecting External Pressure Modules

When an external pressure measurement module is connected and when applicable, MC6-T opens a dialog. Among other information, the dialog includes a possibility to choose where to use the connected external pressure module.

An external pressure module may be disconnected at any time. MC6-T indicates that an external pressure module was removed. If the module was used for a measurement, the measurement stops.



Warning: Select a pressure module that has a suitable measurement range for your pressure signal. Too low/high measurement range on the pressure module results in faulty modules, imprecise readings or even accidents.

Zeroing a Pressure Module

If the selected pressure module does not display zero gauge pressure when the applied pressure is zero, the module has to be zeroed. To do so, apply zero gauge pressure and tap the zero button.



Current Measurement

When measuring electric current, an important thing is selecting whether MC6-T provides the 24 V **loop supply voltage** or not. If not, an external device should provide the loop supply voltage.

Connection depends on the loop supply setting.

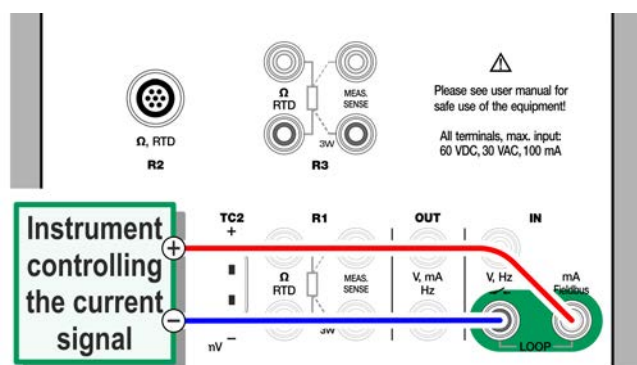

Figure 26: Current measurement terminals. Internal supply Range -101 ... +101 mADC

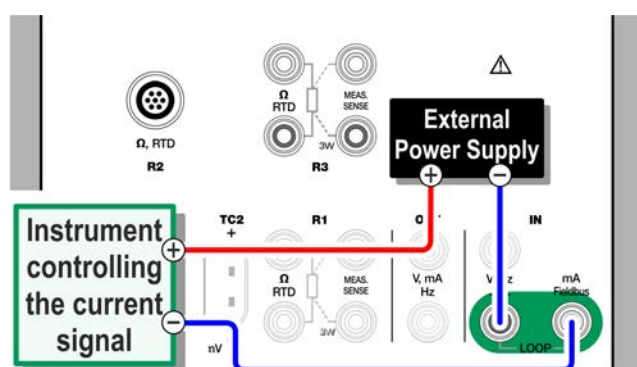

Figure 27: Current measurement terminals. External supply

See also chapter [Current Generation \(Source or Sink\)](#).

Voltage Measurement

MC6-T's voltage measurement terminals are listed below as they are shown in [Figure 28: Voltage measurement terminals](#):

- **TC1**, measurement range: -1.01 to +1.01 VDC.
- **TC2**, measurement range: -1.01 to +1.01 VDC.
- **IN**, measurement range: -1.01 to +60.6 VDC.

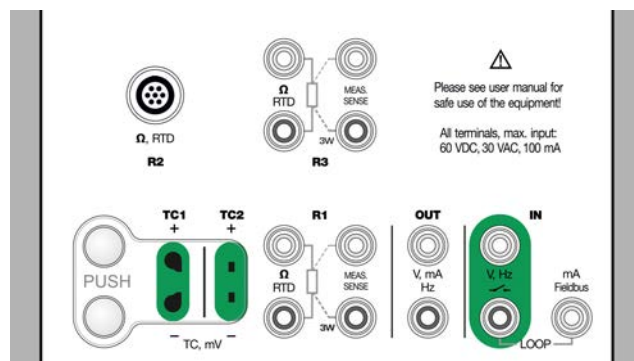

Figure 28: Voltage measurement terminals

Note that you may measure non-supported thermocouple signals using either **TC1** or **TC2** port. The reading is in (milli)volts, so you need a data table to convert the signal to temperatures. **Scaling** tool may be used for converting millivolts to temperatures.



Warning: Do not apply hazardous voltages to MC6-T's terminals.

See also chapters [Voltage Generation](#) and [Temperature Measurement \(Thermocouple\)](#).

Frequency Measurement

In frequency measurement, be sure you select a suitable **trigger level** setting. To do that, tap on the button . From the opened pop-up window: Select a suitable trigger level.

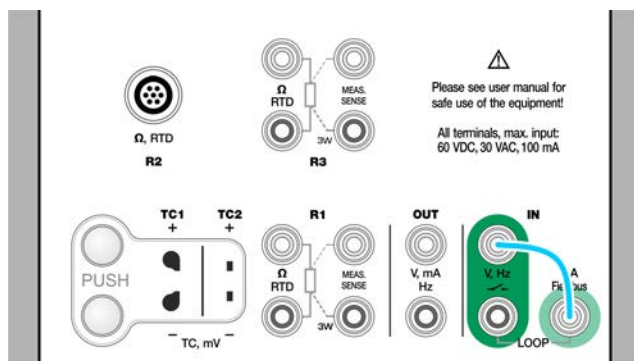

Figure 29: Frequency measurement terminals. Range 0.0027 ... 51000 Hz

See also [Frequency Generation](#), [Pulse Counting](#) and [Switch Sensing](#).



Note: There is a trigger level choice for (dry) contacts with no external potential. 24 V supply may also be used. Connect as light blue line shows in picture above.

Pulse Counting

Pulse counting has three settings that should be checked before (re)starting a pulse count:

- **Trigger level.** Select a level that suits your signal.
- **Trigger edge.** Select either rising or falling edge.
- **Zeroing.** A possibility to zero the pulse count.

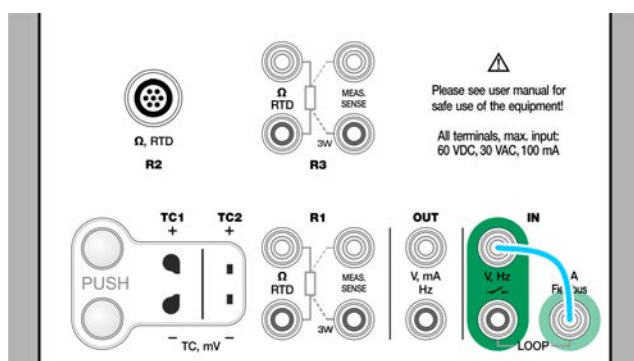

Figure 30: Pulse counting terminals. Range 0 ... 9 999 999 pulses

See also [Pulse Generation](#), [Frequency Generation](#) and [Frequency Measurement](#).



Note: There is a trigger level choice for (dry) contacts with no external potential. 24 V supply may also be used. Connect as light blue line shows in picture above.

Switch Sensing

Switch Sensing has three settings:

- A possibility to **invert** switch's open/close state indication.
- **Trigger level**. Select a level that suits your switch. See note to the right.
- **Sound setting**. Define whether MC6-T emits a sound when the switch's state change and if yes, when it is emitted.

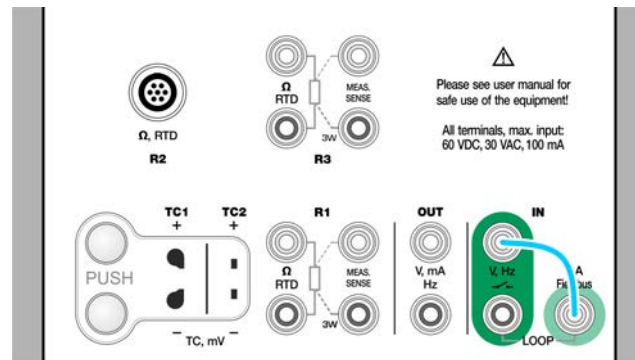

Figure 31: Switch sensing terminals

See also [Pulse Counting](#) and [Pulse Generation](#).



Note: There is a trigger level choice for (dry) contacts with no external potential. 24 V supply may also be used. Connect as light blue line shows in picture above.

You can also use Switch Sensing for binary signal detection. For normal switch state detection: an open switch equals **1 / True** and a closed switch **0 / False**.

Generations/Simulations

Generations and simulations are supported in all operational modes.

Changing the Generated/Simulated Value

There are several ways of changing the generated/simulated value. The following subchapters present the available utilities.

Using the Soft Numeric Keypad

This tool is useful when a generated/simulated value (or any numeric field in MC6-T) is either empty (displaying dashes) or when a new and different

value is needed. The soft numeric keypad opens when you tap on the generated/simulated value (see [Figure 32: Soft Numeric Keypad](#)). Tap on numbers to enter a value. Additional functions:

- Use the "**C**" key on the right to clear the entered value.
- Use the "**Left Arrow**" key to delete the number to the left of the cursor.

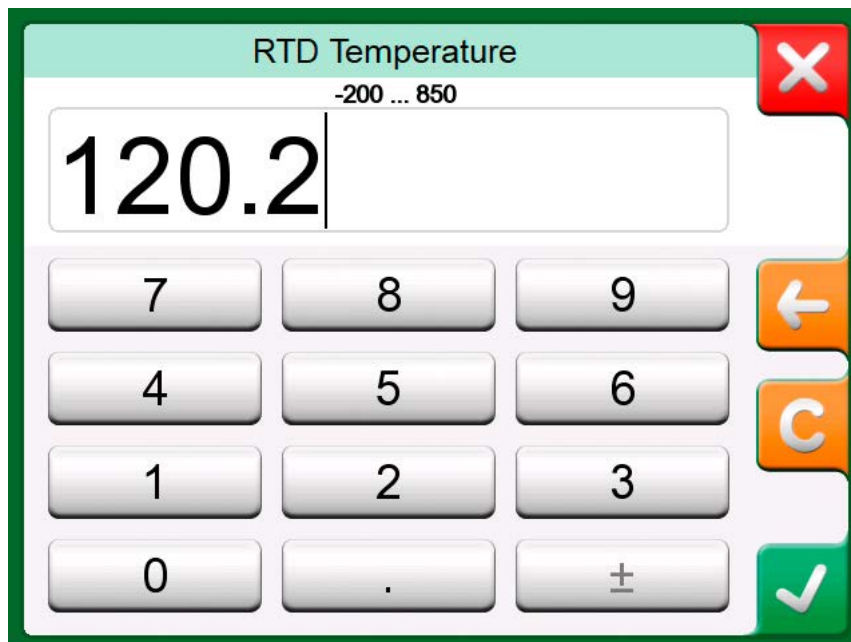

Figure 32: Soft Numeric Keypad

The entered value is taken into use when you close the window using the "**Accept**" button. Note that MC6-T may use the entered value as a source for the value's resolution. Enter trailing zeros to ensure useful resolution.

When applicable, the minimum and maximum limit of the entered value is shown above the entered number. If you enter a value above/below the limits, and try to accept it, MC6-T stays in the soft numeric keypad window and replaces the entered value with appropriate limit value and highlights the replaced value.

Spinning

Spinning is a tool that is available in **Calibrator** and **Documenting Calibrator**. It is useful when making small changes to an existing numeric value, one digit at a time.



Figure 33: Inactive spinner



Figure 34: Active spinner

Non-empty numeric fields in Calibrator's generation/simulation windows have a button with both "Up" and "Down" arrows to the left of the actual numeric value. That is the **Spinner** button. Tap the **Spinner** button to activate spinning.

When spinning is active, one of the digits is highlighted. Change its value by tapping the "**Up**" and "**Down**" arrows in the active spinner. To move the highlight to another digit, use the "**Left**" and "**Right**" arrows.

To stop spinning, tap the **Spinner** button again.



Note: Any changes in the numeric field are immediately reflected in the generated/simulated signal. You cannot exceed the minimum/maximum limits of a Function when spinning. The spinned value follows the resolution properties of the generated/simulated Function. If a numeric field is empty (displaying dashes), first use the soft numeric keypad to enter a value. Then you are able to utilize the spinning tool.

Temperature Generation

When using the **Temperature Block** to generate temperature, an essential decision is whether to use internal or external reference sensor. Using an accurate **external reference sensor** results in a more accurate calibration with smaller uncertainty, compared to using the **internal reference sensor**. The internal reference sensor is permanently installed into the Temperature Block, therefore it does not directly measure the temperature of the insert. The external reference sensor, on the other hand, is inserted into the insert, significantly closer to the temperature probe or instrument to be calibrated. For details see [Figure 35: Internal vs External reference sensor](#).

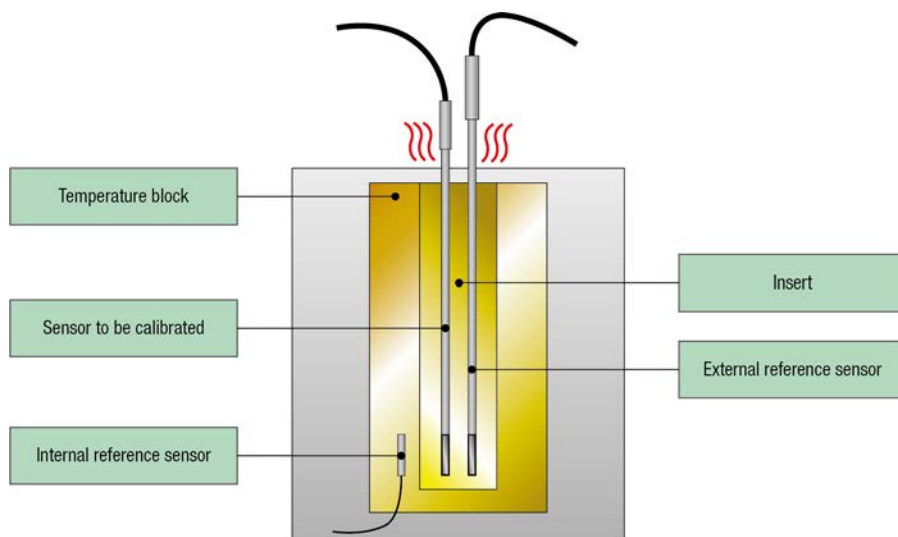

Figure 35: Internal vs External reference sensor

When using internal reference sensor, no connections are needed. Select the Internal Reference in the Temperature Calibrator or use **Temperature Instrument – Wizard** in Documenting Calibrator.

When using external reference sensor, any of the five temperature measurement ports can be used. See the connections in sections [Temperature Measurement \(RTD\)](#) or [Temperature Measurement \(Thermocouple\)](#).



Note: Temperature changes relatively slowly and it takes time for the temperatures to stabilize enough to record the measurement results. See more about stability in section [Tools](#).



Note: Choose a reference sensor that has suitable accuracy for the instrument to be calibrated. Typically, RTDs are more accurate than thermocouples.



Note: When calibrating an instrument using **automatic acceptance**, ensure that the wait time is long enough for the temperatures to stabilize. The time depends on several parameters, e.g. how well the sensor fits into the insert and what is the thermal conductivity between the insert and sensor and also within the sensor itself. Be patient.

Inserts to be used in the Temperature Block



Warning: For reliable and safe performance of the calibrator, only use original Beamex MC6-T inserts.



Warning: Always remove the insert when not using device. Use the insert removal tool for removing the insert.



Warning: Never place a hot insert in accessory holder or carry case (optional accessories). The insert must not be removed from or inserted in the Temperature Block when block temperature is above 50 °C.



Note: Inserts must be heated to maximum block temperature before first use, and kept there for 30 minutes.



Note: Use insert with suitable sized holes for the temperature probes and instruments to be calibrated and external reference sensor. Diameter of the boring may be at most 0,5 mm larger than the outer diameter of the instrument to be calibrated.



Note: Avoid scratching or denting the inserts. Only use clean, undamaged inserts.

Thermocouple Simulation

Thermocouple simulation is available from TC1 terminals only.

Check the **Sensor Type**. Your simulations are unreliable unless you select the same sensor type as is connected to MC6-T. Also select a suitable **Reference Junction** compensation method. Wrong Reference Junction setting yields useless results. See chapter [Thermocouple Connections](#).

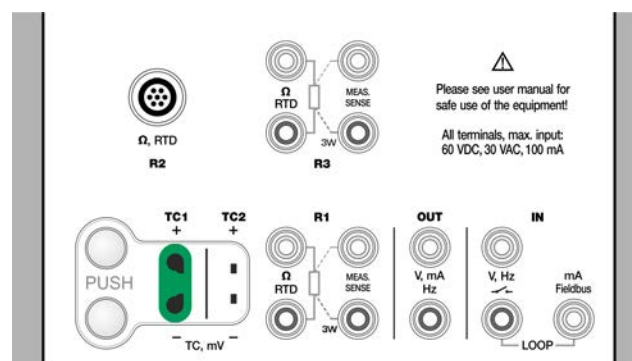

Figure 36: Thermocouple simulation terminals. Range depends on selected sensor type

See also [Temperature Measurement \(Thermocouple\)](#).



Warning: When using a thermocouple or an RTD sensor connected to MC6-T to measure the external reference junction temperature: Keep in mind that there is no galvanic isolation between the sensors.



Note: Thermocouple measurements are error prone. There may be faulty connections, wrong (extension) cables and settings in MC6-T. If unsure, see chapter [Thermocouple Connections](#) and study thermocouple literature.

RTD Sensor Simulation

RTD simulation is available from R1 terminals only.

Use of 2-, 3- or 4-wire connection is up to the receiving instrument. Connect the possible third and fourth wire according to the requirements of the connected instrument, but **use only the two leftmost R1 terminals in MC6-T.**

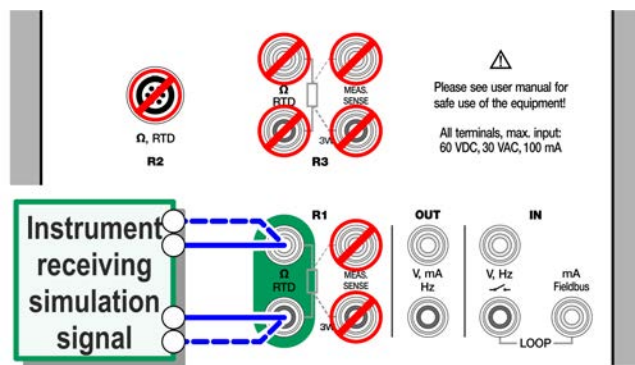

Figure 37: RTD simulation terminals. Range depends on selected sensor type

Check the **Sensor Type**. Make sure you select the same sensor as the instrument receiving the simulated signal requires. Otherwise your simulations are unreliable.

See also [Temperature Measurement \(RTD\)](#) and [Resistance Simulation](#).



Note: To ensure good contact between the device under test and the test leads, we recommend using the alligator clips provided with MC6-T.

AC measurement current from the instrument under test is not supported. With pulsed measurement current, set a wait time of a few milliseconds before the resistance is measured.

Current Generation (Source or Sink)

MC6-T's current generation can be done using one of two available methods:

- MC6-T provides a 24 V loop supply voltage (source mode).
Setting: **Supply: On.**
- An external device provides the loop supply voltage (sink mode).
Setting: **Supply: Off.**

Connection depends on the loop supply setting. See [Figure 38: Current generation terminals. Internal supply. Range 0 ... 55 mADC](#) and [Figure 39: Current generation terminals. External supply.](#)

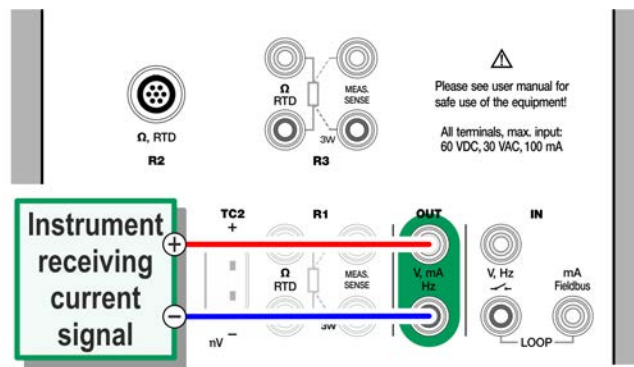

Figure 38: Current generation terminals. Internal supply. Range 0 ... 55 mADC

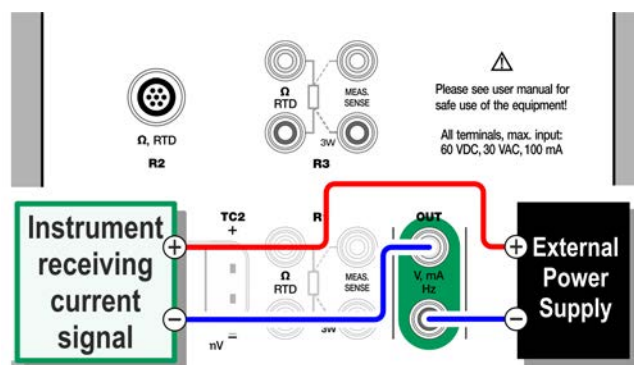

Figure 39: Current generation terminals. External supply

See also [Current Measurement](#).



Note: If the connected instrument utilizes digital communication and 24 V supply voltage is in use, the battery symbol is shown in the user interface of **Documenting Calibrator** and **Data Logger**.

Voltage Generation

MC6-T has two voltage generation terminals as shown in [Figure 40: Voltage generation terminals](#).

- **TC1**, generation range: -1 to +1 VDC.
- **OUT**, generation range: -3 to +24 VDC.

Note that you may simulate non-supported thermocouple signals using **TC1** port. Since you actually generate (milli)volts, you need a data table to convert desired temperatures to millivolts.

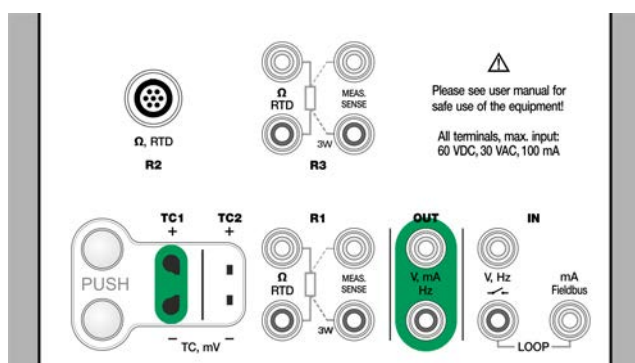

Figure 40: Voltage generation terminals

See also [Voltage Measurement](#) and [Thermocouple Simulation](#).



Note: It is advisable to enter 0 V output before connecting the circuit.



Warning: Short circuiting the voltage output may result in damage to MC6-T and/or the connected instrument.

Resistance Simulation

Resistance simulation is available from R1 terminals only.

Use of 2-, 3- or 4-wire connection is up to the receiving instrument. Connect the possible third and fourth wire according to the requirements of the connected instrument, but **use only the two leftmost RTD1 terminals in MC6-T**. See [Figure 41: Resistance simulation terminals](#). Range 0 ... 4000 Ohm.

MC6-T monitors the resistance measurement current. If the current is too high, MC6-T cannot simulate the right resistance value and displays an error message.

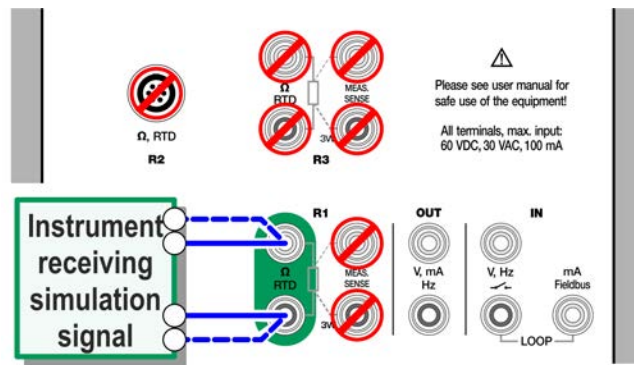

Figure 41: Resistance simulation terminals. Range 0 ... 4000 Ohm

See also [Resistance Measurement](#) and [RTD Sensor Simulation](#).



Note: When simulating resistance or an RTD sensor, using R1 port, MC6-T does not support measuring the simulated signal using R2 port.

To ensure good contact between the device under test and the test leads, we recommend using the alligator clips provided with MC6-T.



Warning: AC measurement current from the instrument under test is not supported. With pulsed measurement current, set a wait time of a few milliseconds before the resistance is measured.

Frequency Generation

Before generating frequencies, the following settings should be checked:

- **Amplitude.** Defined from the button with the "V" value.
- **Waveform** and **Duty Cycle.** Set together from the rightmost button.

Duty Cycle is the ratio of the output high time to the total cycle time. Due to technical reasons, the entered Duty Cycle is not always realized with relatively high frequencies. When the realized Duty Cycle differs from the desired Duty Cycle, the realized Duty Cycle is shown with an asterisk (*) in front of it, e.g.:

□ *8%

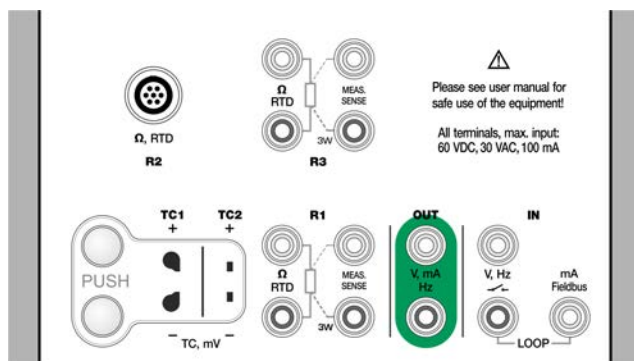

Figure 42: Frequency generation terminals. Range 0.0005 ... 50000 Hz

See also [Frequency Measurement](#) and [Pulse Generation](#).

Pulse Generation

Before generating pulses, the following settings should be checked:

- **Frequency.** To set the frequency, tap on the button with the "Hz" value.
- **Amplitude.** Defined from the button with the "V" value.
- **Waveform and Duty Cycle.** Set together from the rightmost button.

Duty Cycle is the ratio of the output high time to the total cycle time. Due to technical reasons, the entered Duty Cycle is not always realized with relatively high frequencies. When the realized Duty Cycle differs from the desired Duty Cycle, the realized Duty Cycle is shown with an asterisk (*) in front of it, e.g.:

 *8%

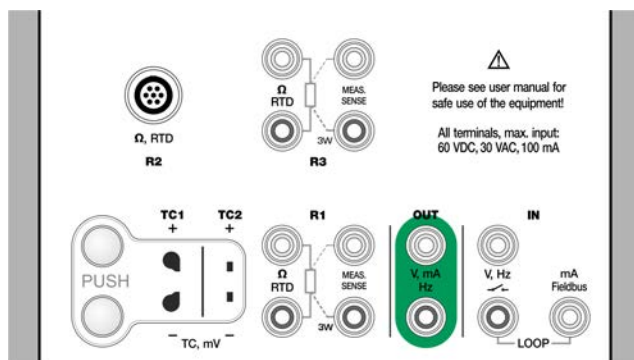

Figure 43: Pulse generation terminals. Range 0 ... 9 999 999 pulses

See also [Pulse Counting](#) and [Frequency Generation](#).

Thermocouple Connections

With thermocouples, connections and reference junction settings are crucial for getting accurate results. Reference Junction Modes available:

Internal is the simplest. Use suitable thermocouple, extension or compensation wires to connect to MC6-T. MC6-T takes care of the Reference Junction compensation. See [Figure 44: Internal Reference Junction](#). You may optionally also use the TC2 terminals.

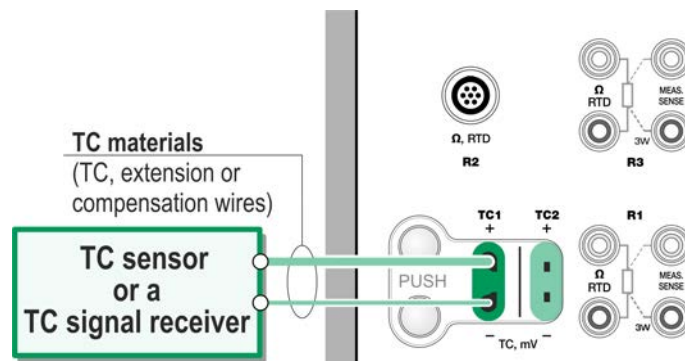

Figure 44: Internal Reference Junction

External R1 and **External R2** use an external RTD sensor measuring the Reference Junction temperature, connected to selected terminal. The [Figure 45: An RTD connected to R1 terminals measures the Reference Junction temperature](#) presents the connections to TC1 and R1 terminals.

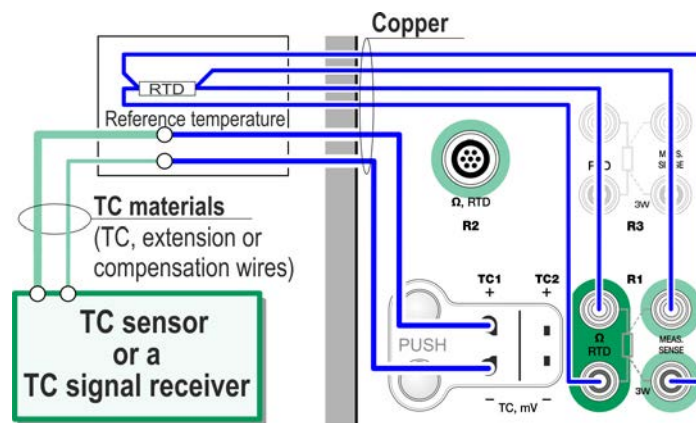

Figure 45: An RTD connected to R1 terminals measures the Reference Junction temperature

Fixed (0 °C) and **Manual** are used when a compensation box, a temperature controller or similar method is utilized for fixing the Reference Junction temperature. **Manual** allows you to enter any temperature. **Fixed (0 °C)** is a quick way of "entering" zero degrees centigrade. Connection picture to TC1 - see [Figure 46: Fixed/Manual Reference Junction temperature](#).

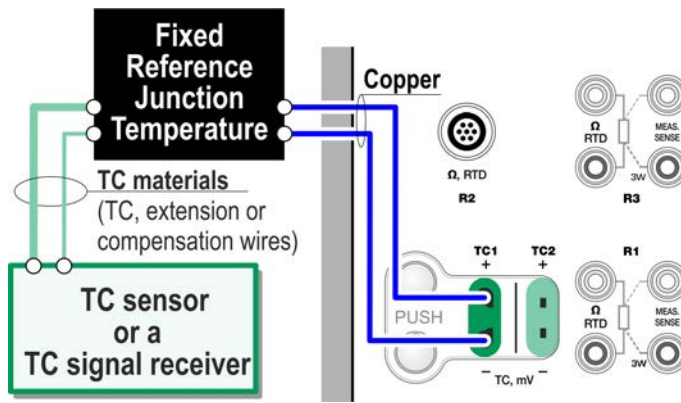

Figure 46: Fixed/Manual Reference Junction temperature



Warning: Before measuring, ensure that device's internal temperature has stabilized. Temperature differences between MC6-T and the environment affect the accuracy of TC measurements. In extreme conditions, wait up to 90 minutes.

Tools

MC6-T has **Tools** buttons in the lower left corner of certain subwindows. The lists in the following subchapters present available tools. Certain tools are available for measurements only and others for generations/simulations only.



Figure 47: Tools button



Note: The available tools also depend on the selected Quantity and Function, e.g. Switches have limited amount of tools.

Several tools have a **"Stop"** button in the pop-up window the Tool is configured in. To stop, e.g. Damping, open the Damping configuration window and tap the **"Stop"** button. Then MC6-T reverts to default damping settings.

Changing the Quantity of a subwindow reverts all Tools, except Additional Info settings, to their default settings for that particular Quantity.

In **Calibrator** window: the additional info fields with black text may be zeroed "on the fly". Zeroing options are available in **Additional Info** window's menu.

Tools for Measurements

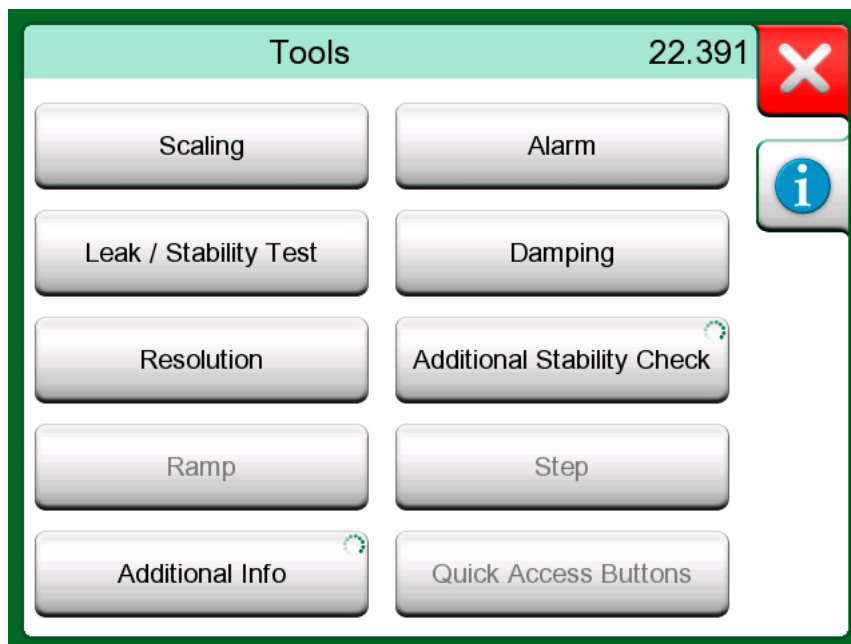





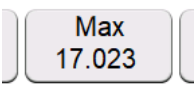



Figure 48: Tools for measurements (as seen in Temperature Calibrator)

Tool	Description	Available in
Scaling 	<p>Any signal may be scaled provided the conversion is known. When scaling is active, it is indicated with a triangle in the unit button. The true measurement value is shown in the additional info row at the bottom of the subwindow.</p>	<ul style="list-style-type: none"> • Temperature Calibrator • Calibrator • Documenting Calibrator* • Data Logger <p>* Scaled units are not supported in CMX nor in LOGiCAL.</p>
Alarm 	<p>Main measurements may be assigned with four alarm limits: high, low, high and low change rate. Active alarms are shown above the main measurement. When an alarm limit is exceeded, a warning signal is heard. A button for acknowledging an alarm appears when needed.</p>	<ul style="list-style-type: none"> • Temperature Calibrator • Calibrator

Tool	Description	Available in
Leak / Stability Test	<p>A leak/stability test may be assigned to main measurements. It tests the leak or stability of, e.g. a pressure measurement system.</p> <p>In the Leak / Stability Test configuration window: Enter Test time and start recording. Use the "+30 sec" button to increase the test time, when needed.</p>	<ul style="list-style-type: none"> • Temperature Calibrator • Calibrator • Documenting Calibrator • Data Logger
Damping 	<p>Use damping when a measurement signal contains unwanted noise. Select one of the available options.</p> <p>When Damping is used, a funnel appears to the left of the main measurement. When damping is active, the following symbol is shown above the unit button:</p> 	<ul style="list-style-type: none"> • Temperature Calibrator • Calibrator • Documenting Calibrator • Data Logger
Resolution 	<p>Any signal's resolution may be increased or decreased. Altered resolution is indicated in sub-window, e.g. "-2" equals two less decimals.</p>	<ul style="list-style-type: none"> • Temperature Calibrator • Calibrator • Documenting Calibrator • Data Logger

Tool	Description	Available in
Additional Stability Check	<p>Additional Stability Check is available for temperature measurements. It is an addition to the default stability check ensuring that slow temperature transients are handled correctly. For more information see chapter Additional Stability Check.</p>	<ul style="list-style-type: none"> • Temperature Calibrator • Calibrator • Documenting Calibrator* • Data Logger <p><i>* CMX has fixed default of 1 min when sending to calibrator, but if user changes it in the calibrator, it will be received by CMX and stored with the results.</i></p>
Additional Info 	<p>Including additional information fields at the bottom of a subwindow is always available. The available fields, however, depend on the quantity/ settings. Up to four fields may be added to both subwindows. The additional information row settings are saved for future needs.</p>	<ul style="list-style-type: none"> • Temperature Calibrator • Calibrator
Function Info 	<p>Always available. Opens a pop-up window with information of current function (measurement range, uncertainties etc.).</p>	<ul style="list-style-type: none"> • Temperature Calibrator • Calibrator • Documenting Calibrator • Data Logger



Note: In **Temperature Calibrator** or **Calibrator** also the Additional Information row settings for all functions are saved for future needs. However Damping, Resolution and Alarms are active for the current session only.

Additional Stability Check

The **Additional Stability Check** is an enhanced method for determining when a temperature signal is stable enough for reliable calibration. The **Additional Stability Check** tool can be activated for the Internal Reference, RTD and TC sensor measurements. The user can select

either 1 or 2-minute time window for the rolling 2 x STDDEV (2σ) stability calculation. Temperature generation in the Temperature Block always use 1-minute **Additional Stability Check**.

When **Additional Stability Check** has been enabled for a temperature measurement, the calculated 2σ Stability value can be seen e.g. in an **Additional Info** box below the measurement or in the temperature graph as a thin line.

The temperature signal is determined to be stable (unstable symbol disappear) when the 2σ Stability value is below the Stability Limit ($2\sigma \leq$). The Stability Limit corresponds to the stability specification of the **Temperature Block**. Please check the detailed specifications of the device. Notice that the Internal Reference and the Temperature Block do not have a valid Stability Limit for temperatures outside the specification temperature range, i.e. the unstable symbol will never disappear outside this range. For RTD and TC sensors however, the Stability Limit is valid and extends outside this range with constant values.

Tools for Generations/Simulations

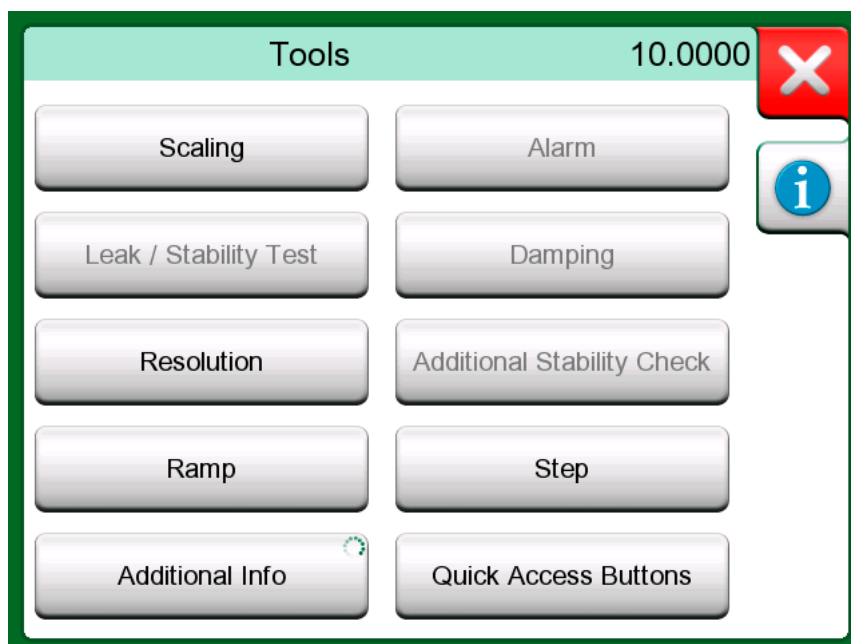









Figure 49: Tools for generations and simulations (as seen in Calibrator)

Tool	Description	Available in
Scaling 	Any signal may be scaled provided the conversion is known. When scaling is active, it is indicated with a triangle in the unit button. The true measurement value is shown in the additional info row at the bottom of the subwindow.	<ul style="list-style-type: none"> • Temperature Calibrator • Calibrator • Documenting Calibrator* • Data Logger <p>* Scaled units are not supported in CMX nor in LOGiCAL.</p>
Resolution 	Any signal's resolution may be increased or decreased. Altered resolution is indicated in sub-window, e.g. "-2" equals two less decimals.	<ul style="list-style-type: none"> • Temperature Calibrator • Calibrator • Documenting Calibrator • Data Logger
Step 	Available for generations/simulations: Opens a window for defining a step function for the generated/simulated signal. Step time option defines delay time	<ul style="list-style-type: none"> • Temperature Calibrator • Calibrator • Data Logger

Tool	Description	Available in
	which starts after stability criteria has been met.*	

* The Step option includes the possibility to use steps when increasing/decreasing the temperature. It is usable, if you manually document the calibration data. When using the Step tool, it is recommended to activate the tool's stability check. This is to ensure that the temperature has stabilized before next step.

Tool	Description	Available in
Ramp 	Available for generations/simulations: Opens a window for defining a ramp function for the generated/simulated signal.	<ul style="list-style-type: none"> • Calibrator
Quick Access 	Available for generations/simulations: Opens a window for defining five shortcuts to user configurable generation/simulation values. Quick Access buttons appear at the bottom of the subwindow, taking over the space of possible additional info data.	<ul style="list-style-type: none"> • Calibrator
Additional Info 	Including additional information fields at the bottom of a subwindow is always available. The available fields, however, depend on the quantity/settings. Up to four fields may be added to both subwindows. The additional information row settings are saved for future needs.	<ul style="list-style-type: none"> • Temperature Calibrator • Calibrator
Function Info 	Always available. Opens a pop-up window with information of current function (measurement range, uncertainties etc.).	<ul style="list-style-type: none"> • Temperature Calibrator • Calibrator • Documenting Calibrator • Data Logger

Temperature Calibrator

Things discussed in this chapter:

- MC6-T's Temperature Calibrator for calibration of temperature instruments and sensors

About Temperature Calibrator

Temperature Calibrator operational mode has been optimized for temperature calibrations. Any supported RTD and thermocouple sensor may be calibrated as well as any temperature instrument if the output signal can be read by MC6-T. Up to three instruments may be calibrated simultaneously.

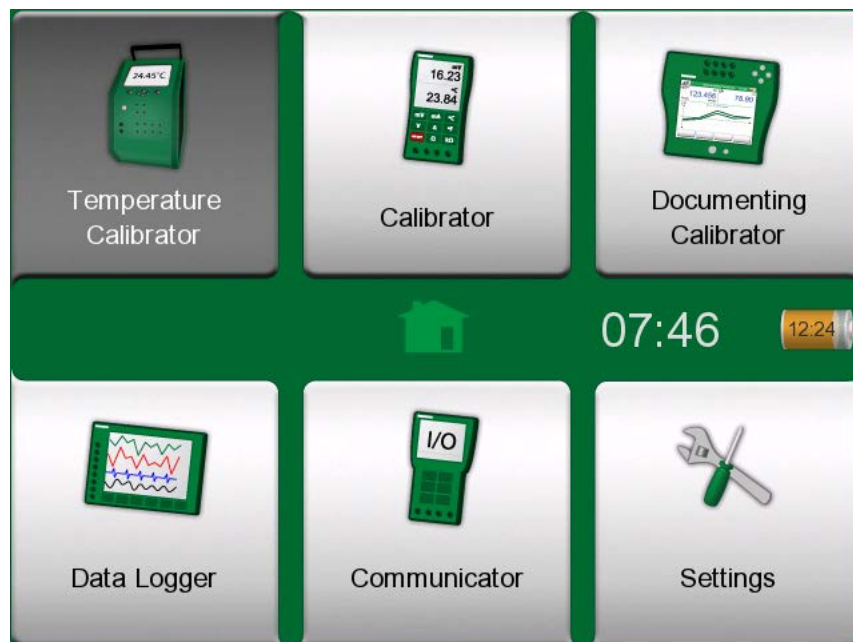

Figure 50: Home View with Temperature Calibrator selected



Note: Keyed output is not supported in Temperature Calibrator. Temperature Calibrator requires that the Mains switch is on.

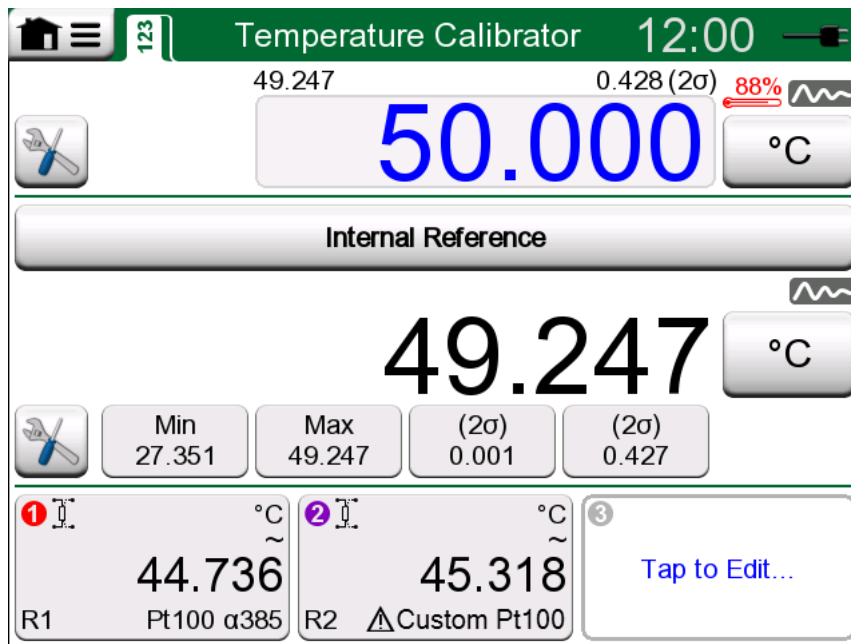

Figure 51: Temperature Calibrator, main view

The three parts of Temperature Calibrator's main view (separated by green horizontal bars):

1. The **upper** part is for entering the Temperature Block's set point.
 - The small number above the set point and on the left is the internal reference sensor's temperature.
 - The small number above the set point and on the right is the internal reference sensor's temperature measurement's stability (2σ).
 - The red "thermometer" and a percentage value indicates that currently MC6-T is heating with 88 % power. If the "thermometer" is blue, MC6-T is cooling the Temperature Block.
 - The tools button on the bottom left is described in chapter [Tools](#).
2. The **middle** part is for selecting the reference sensor and viewing the temperature:
 - The button on top of the subwindow is for selecting what is used as reference sensor. The available options are: the internal reference sensor or any sensor connected to RTD or thermocouple connected to MC6-T. If the internal reference sensor is not used, place the external reference sensor in the Temperature Block's insert.
 - Use the **Tools** button to select which additional information is shown in the lower part of the subwindow. Stability reading (2σ) and unstable indicator are recommended to be viewed. They indicate when the temperature is stable enough to manually document the results.
3. The **lower** part has three channels for configuring instruments to be calibrated. Tap within the channel's frame to select quantity, port/function etc. Any available function can be selected, selection is not limited to temperature quantities.



Note: Tap on the title bar of Temperature Calibrator's window to toggle between main view and **graph view**. The active area is indicated in the [Figure 53: Title bar's active area \(shown in yellow\) for toggling between main view and graph view](#).

The **graph** view presents a graphical view of the measurements defined in the three channels. The thick lines are the temperature measurements, y axis on the left. Corresponding thin lines presents the stability of the temperature measurements, y axis on the right. To see which line relates to which channel, tap on the graph. A legend pops up as in the [Figure 52: Temperature Calibrator, graph view](#).

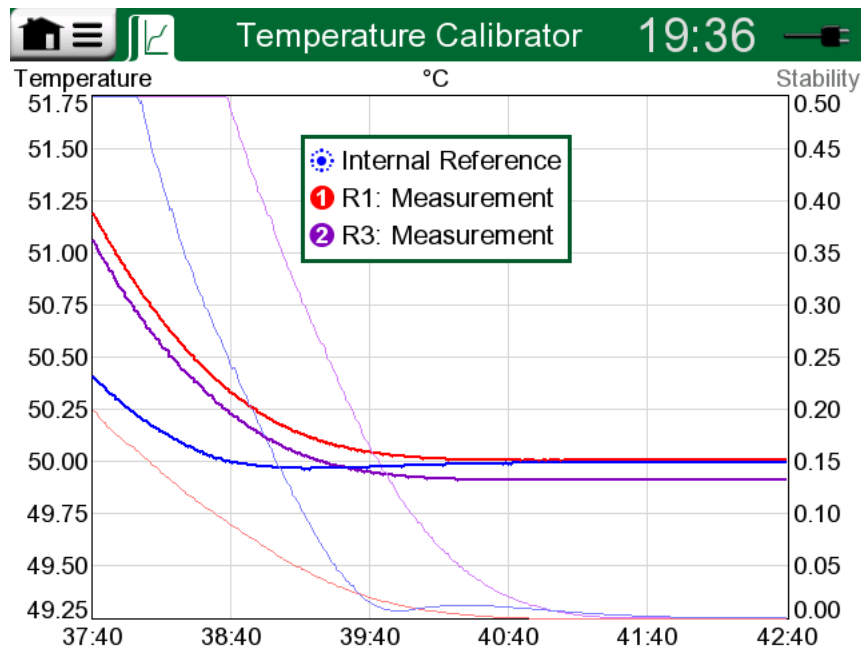

Figure 52: Temperature Calibrator, graph view

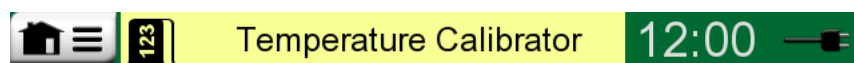

Figure 53: Title bar's active area (shown in yellow) for toggling between main view and graph view



Note: If you want to document your calibration results, use MC6-T's **Documenting Calibrator** feature or manually document the calibration data displayed in **Temperature Calibrator**.

The Menu

The menu in Temperature Calibrator contains the following items:

- **Toggle View** for changing between the main view and graph view (same as tapping on the title bar's active area for toggling view).
- **Reset Graph** for clearing the trend lines. MC6-T recalculates the minimums and maximums based on current measurements/calculations.
- **Settings** opens a window for configuring how the heating and cooling is done. The default values for both heating and cooling is maximum speed, but when using, e.g. sensitive sensors, you may set custom limits.

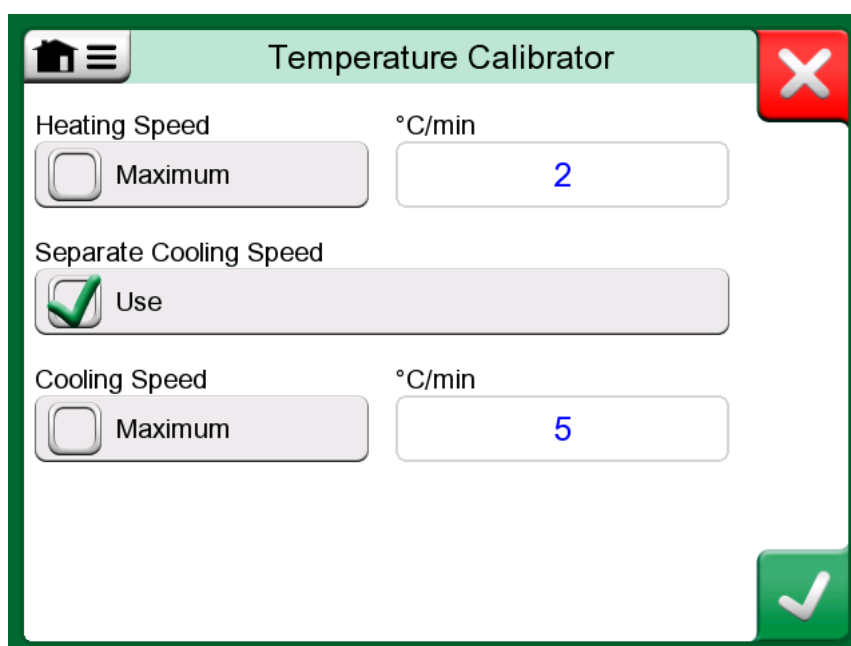

Figure 54: Temperature Calibrator's Settings Window

The Heating Speed and Cooling Speed settings can be lowered to prevent damage to certain sensitive temperature probes.



Note: Although it is possible to change the Heating Speed and Cooling Speed settings on-the-fly while the Temperature Block is being heated or cooled, for sensitive temperature probes it is recommended to set the required Heating Speed and Cooling Speed settings first, and then change the temperature set-point. This prevents unwanted oscillations in the temperature change rate.

Calibrator

Things discussed in this part:

- How to use the Calibrator

About Calibrator

The **Calibrator** can be used for manually calibrating instruments. It consists of two subwindows which can be independently configured to measure, generate or simulate a signal. For example one subwindow for the instrument's input and another for the instrument's output.

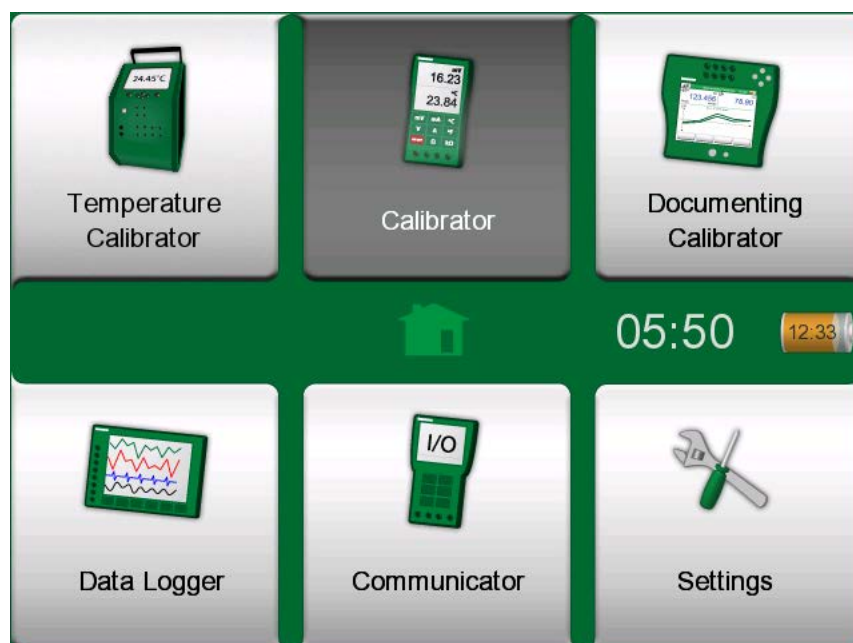

Figure 55: Home View with Calibrator selected

Start the **Calibrator** by tapping on the Calibrator icon in MC6-T's Home View (see [Figure 55: Home View with Calibrator selected](#)). A window like the one in [Figure 56: Calibrator in use](#) opens. To configure a subwindow do as follows:

- Select the **Quantity** of the signal by tapping the button in the upper left corner of the subwindow. Hint: Quantity button has bold font.
- Other, Quantity dependent settings appear to the right of Quantity button. The button closest to the Quantity button defines whether you measure, generate or simulate a signal and which terminals are active.

For information on connections and essential settings, see chapter [Active Terminals and Connections](#).

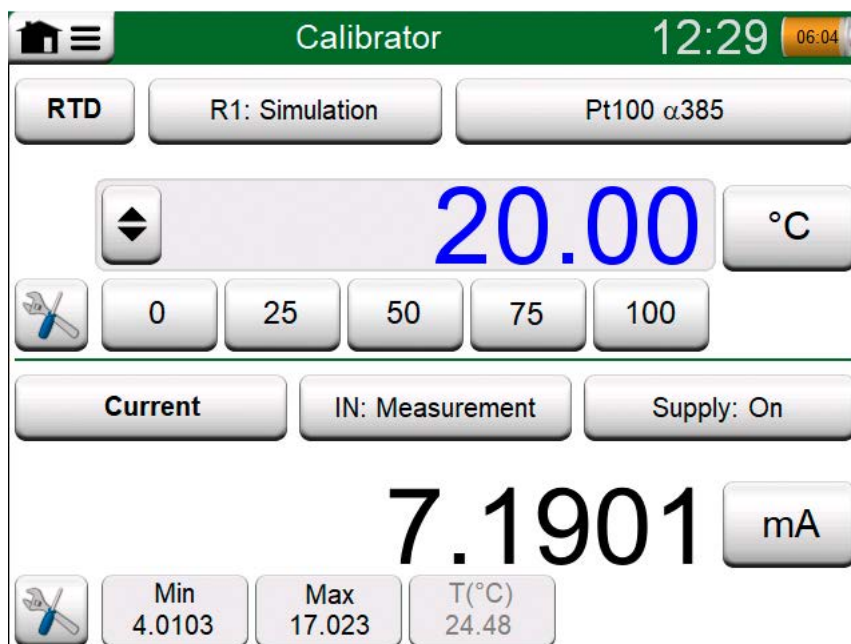

Figure 56: Calibrator in use



Note: There is a special use case built into Calibrator mode: When one subwindow is a generation, and the other a switch, the switch will capture the output value from the other channel when the switch actuates. This allows manual calibration of switches. Note however, that proper calibration of temperature switches should be done in Documenting Calibrator.



Note: If you want to automatically document your calibration results, use MC6-T's **Documenting Calibrator** feature.

For information on External Devices (Pressure and Temperature Controllers) used together with Calibrator, see chapter [Additional Information](#).

Documenting Calibrator

Things discussed in this part:

- An introduction to calibration
- How to calibrate instruments using MC6-T's Documenting Calibrator
- How to view calibration results
- How to read instrument data from devices using digital communication.

General

MC6-T's **Documenting Calibrator** is a more advanced tool than the "plain" **Calibrator** that is also available in MC6-T.

Configurations of the instruments to be calibrated may be received from calibration software communicating with MC6-T. Alternatively, instruments may be created in MC6-T itself.

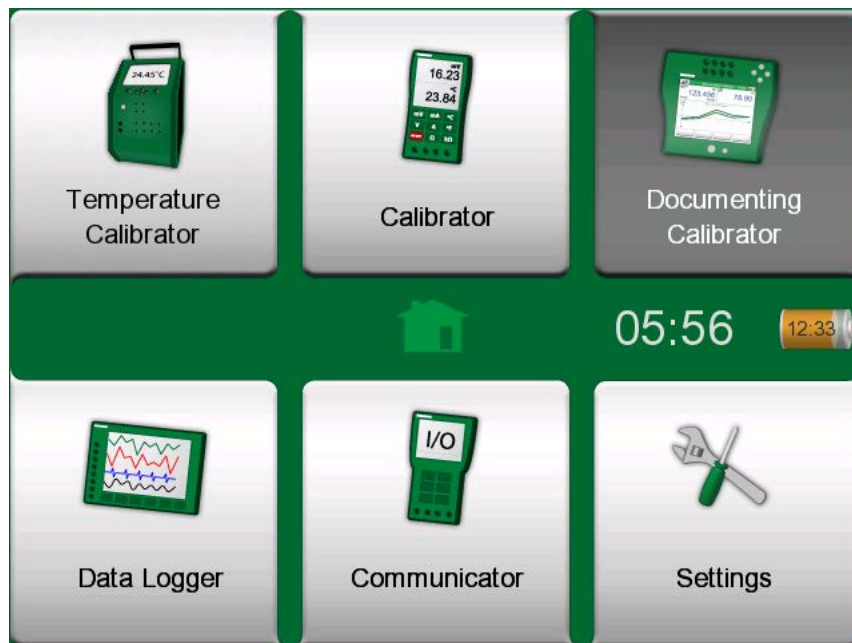

Figure 57: Home View with Documenting Calibrator selected

Documenting Calibrator saves instrument data and presents it in a list. Instrument data consists of input and output quantities and ranges as well as other data that defines the instrument. Starting to calibrate an instrument is fast, since all the required data can be used immediately.

Calibration results are saved and they can be viewed in MC6-T and also sent to calibration software for further analysis.

Open **Documenting Calibrator** by tapping on the **Documenting Calibrator** icon in MC6-T's Home View (see [Figure 57: Home View with Documenting Calibrator selected](#)).

Calibration Software

When this manual was printed, the following calibration software supported communication with MC6-T:

- **Beamex CMX Calibration Software**, version 2.12 and later versions of CMX Professional and Enterprise editions.
- **Beamex LOGiCAL**, version 2, a cloud based calibration management software.



Note: Older Beamex calibration software do not support MC6-T.

Calibrating Instruments

Instruments are typically calibrated following the procedure shown in [Figure 58: Typical calibration procedure](#).

In MC6-T, you first select (or create) the instrument to be calibrated. Then perform the As Found calibration – as many repeats as is required - and decide whether or not adjustment is needed. Often you then do the required amount of As Left repeats to document the instrument's state after the possible adjustment.

A calibration procedure using MC6-T is presented in the following subchapters.

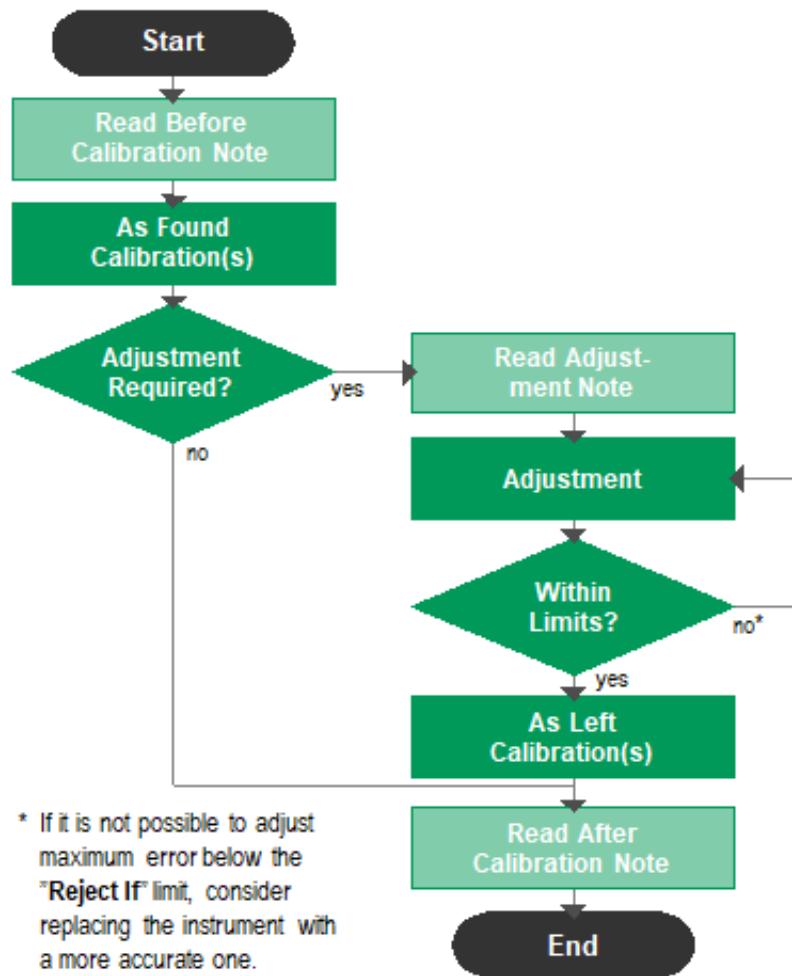

Figure 58: Typical calibration procedure



Note: Although MC6-T assists you in doing the calibration, you need to know how instruments are calibrated; be, e.g. a calibration technician. **MC6-T is a tool for calibration professionals.**

Generating/Simulating the Input Value

How you change the generated/simulated value is explained in chapter [Active Terminals and Connections](#), subchapter [Changing the Generated/Simulated Value](#).

Instrument List

When you start the Documenting Calibrator, you arrive in **Instrument List** window. See [Figure 59: Example of an Instrument List](#) for an example of an Instrument List.

MC6-T allows you to hierarchically organize your instruments into a Plant Structure. The Instrument List window may contain both instruments (gray items) and Plant Structure Levels (yellow items). The following subchapters present features available in Instrument List window and its menu.

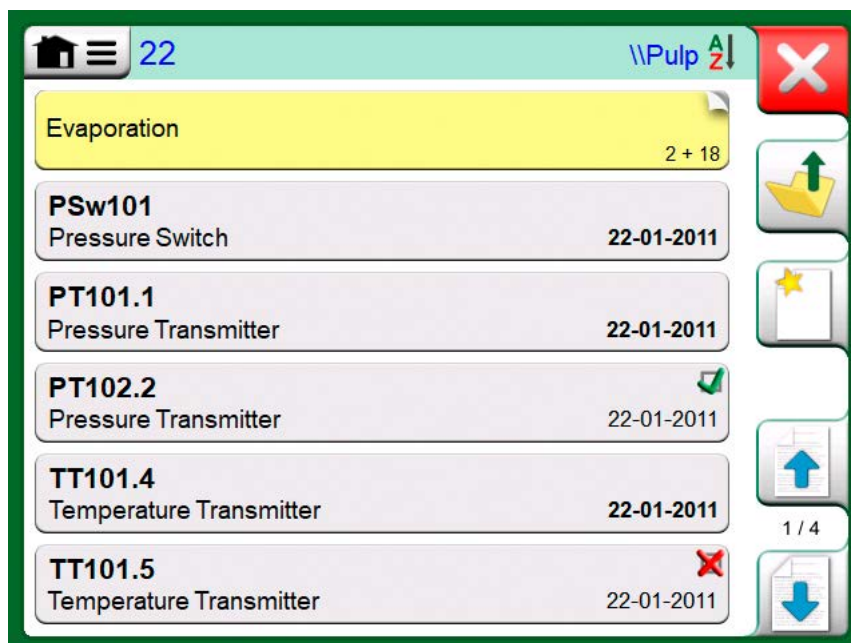



Figure 59: Example of an Instrument List

See also [Work Order View Mode](#).

 **Note:** The Instrument List may be several pages long. Remember to use the page browse buttons available on the right side of the window.

Instruments

Instruments have a gray background in the Instrument List window. The instrument's upper text row displays the contents of one of the following fields: **Position ID**, **Name**, **Device ID** or **Device Serial Number**. The first non-empty of the aforementioned fields, in presented order, is displayed. The second row displays (possible) Function Name and Calibration Due Date data.

If the instrument has been calibrated, the rightmost end displays an icon. The displayed icon depends on whether the **instrument's** latest calibration "**Passed**", i.e. the found maximum errors were smaller than the instrument's "**Reject If**" error limit, or did it "**Fail**".

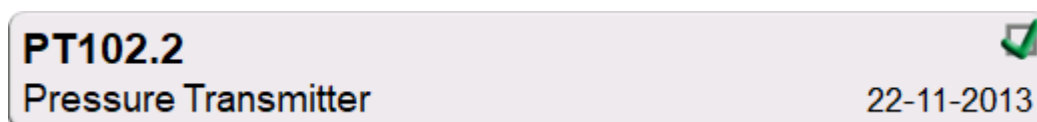

Figure 60: Instrument's latest calibration "Passed"

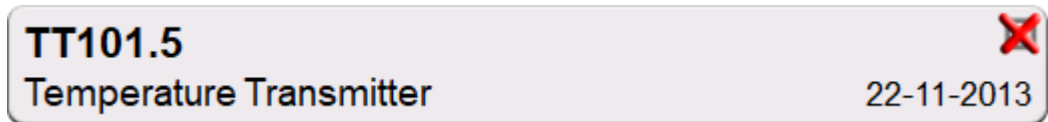

Figure 61: Instrument's latest calibration "Failed"

To **select** an instrument for calibration, tap on it. Then the **Instrument Overview Window**, opens.

Creating Instruments

To create a **new instrument**, tap the "Create New Instrument" button. See **Figure 62: "Create New Instrument" button**.



Figure 62: "Create New Instrument" button



Note: For temperature instruments, you can use **Temperature Instrument - Wizard**, which can be found in the context-sensitive menu that appears after pressing the Menu button (see **Figure 63: Documenting Calibrator, Temperature Instrument Wizard**).

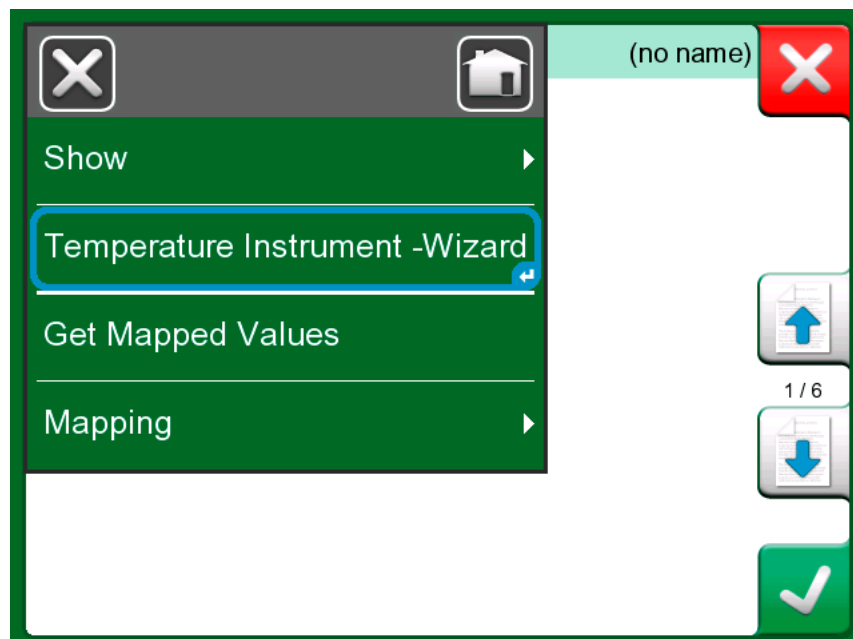

Figure 63: Documenting Calibrator, Temperature Instrument Wizard

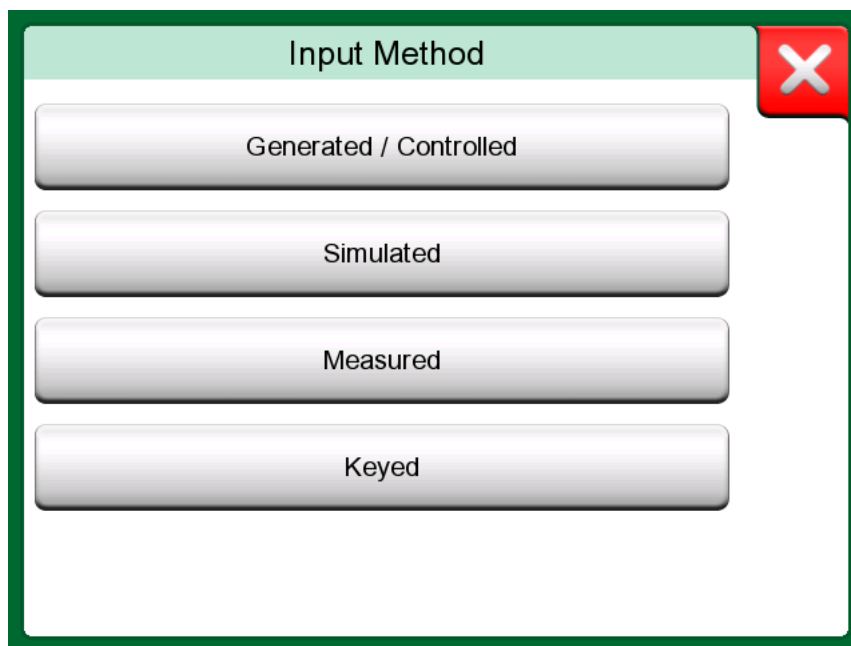

Figure 64: Temperature Instrument Wizard, Input Method

Available methods for calibrating temperature instruments are:

- **Generated/Controlled** (available when Temperature Block is enabled)
 - calibrator generates the temperature with internal Temperature Block or controls the temperature generation by an external device. This method can be used with internal or external reference sensor (see figure [Figure 65: Documenting Calibrator, reference sensor selection dialog](#));
- **Simulated** - calibrator simulates the temperature;
- **Measured** - calibrator measures the temperature but does not control it;
- **Keyed** - measurement value is manually entered into the calibrator;

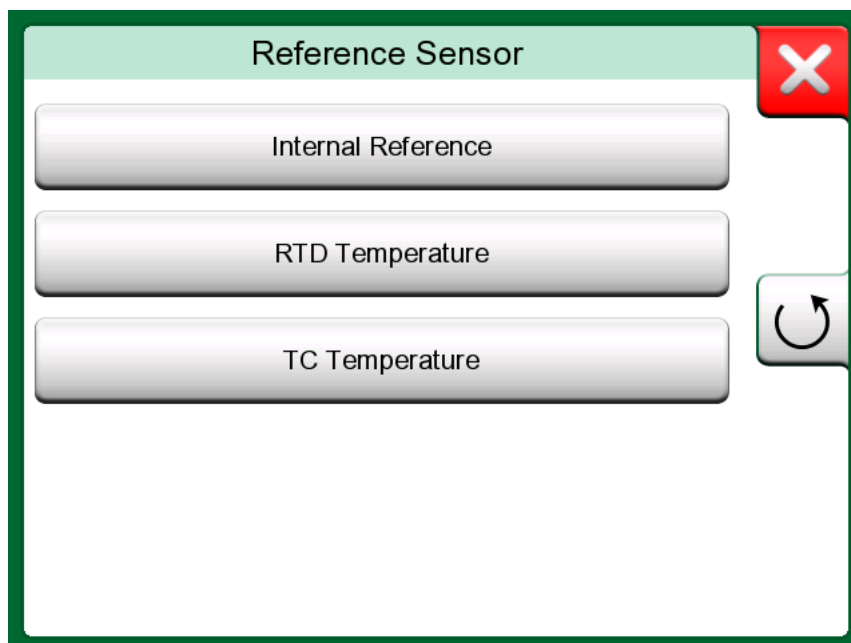

Figure 65: Documenting Calibrator, reference sensor selection dialog

If RTD Temperature or TC Temperature is selected, the option Automatic Control will appear. Calibrator will set the calibration points.

Continue the instrument setup by modifying several pages of instrument configuration data. Note that by default only basic pages are shown. View all pages by selecting **Show, All Pages** from the menu available when creating/editing an instrument.

Basic pages

First page of the creating new instrument configuration data is **Input** related. For all input quantities (except Keyed option), parameters **Port / Function** and **Unit** are available. Depending on selected **Quantity** and Port / Function, other fields will become available for setup (see table [Table 1: Input parameters depending on the selected Quantity](#)).

Table 1: Input parameters depending on the selected Quantity

Quantity	Additional available settings
RTD Temperature	Sensor Type, Automatic control
TC Temperature	Sensor Type, RJ Mode, Automatic control
Pressure	Pressure Type
Current	Loop Supply
Frequency	Amplitude, Waveform & Duty Cycle, Trigger Level
Pulse	Amplitude, Waveform & Duty Cycle, Frequency, Trigger Level, Trigger Edge
Keyed	Keyed Quantity, Unit, Resolution, Resolution from Entry

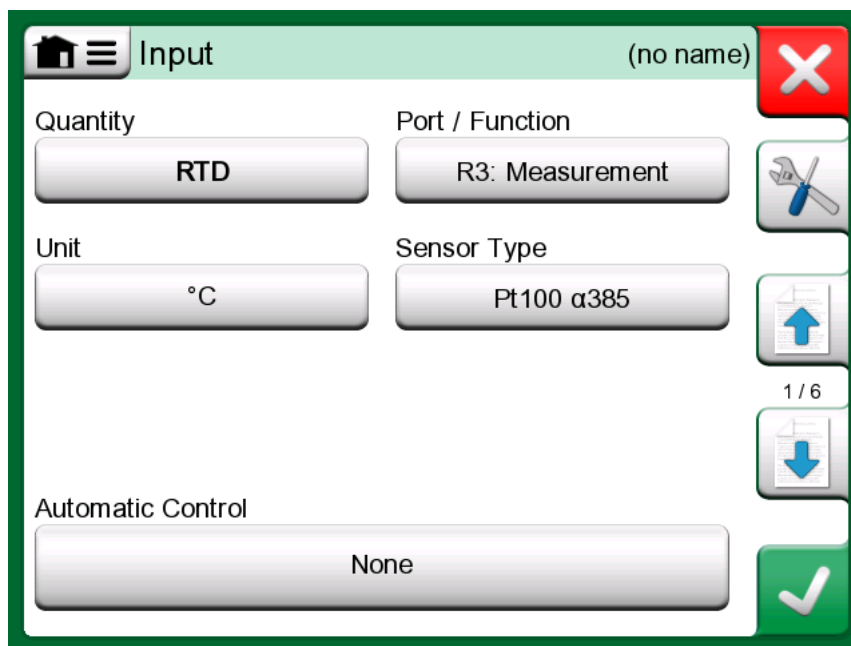

Figure 66: Creating new instrument - configuration, page 1

Second page of the creating new instrument configuration data is **Output** related. For most of the Quantities same parameters are available, with couple of additional settings (see table [Table 2: Additional Output parameters](#)).

Table 2: Additional Output parameters

Quantity	Additional available settings
Switch	Switch Type, Switch Sound, Trigger Level
Keyed	Display Type

Third page of the creating new instrument configuration data (**Function**) allows to modify following parameters:

- Input Range - range of the Input, shown in Input Quantity related units (e.g. Temperature - °C, Current - mA, etc.);
- Transfer Function - defines the relationship between instrument's input and output (e.g. Linear, Square Root, etc.);
- Output Range - range of the Output, shown in Output Quantity related units;
- Function name;

Figure 67: Creating new instrument - configuration, page 3

Fourth page of the creating new instrument configuration data (**Procedure**) describes parameters:

- Calibration Points (Predefined) - define own calibration steps (number of steps, step size and percentage) or select one of the predefined sets;
- Repeat Format - defines way of advancing for calibration points;
- Max Point Deviation (%) - specifies how much the saved calibration point can differ from the nominal calibration point;
- Point Delay (s) - defines how long the device will wait before accepting the point (automatic acceptance checked);
- Points are Input / Output - specifies if the calibration points are calculated from input or from output;
- Stability Check - instrument checks the signal stability before saving the reading;
- Automatic Acceptance - accepts points automatically after considering all preconditions (e.g. point delay, stability, etc.);

Figure 68: Creating new instrument - configuration, page 4

Fifth page of the creating new instrument configuration data (**Error Limit**) allows to select Error Calculation Method (Error Unit and Error Reference). It also serves as a place to set up the measurement error limits (instrument range can be divided up to 10 subranges, each having their own error limit).

Figure 69: Creating new instrument - configuration, page 5

Last page of the basic configuration (**Identification**) gives an opportunity to define Position ID, Name, Device ID and Device Serial Number.



Note: If you plan to transfer the result to CMX or to LOGiCAL, it is highly recommended that at minimum, the *Position ID* and the *Device ID* fields are filled, as they are required fields in the calibration management software.

Figure 70: Creating new instrument - configuration, page 6

Advanced pages



Note: Page numbering changes when all pages are shown.

First page of the advanced configuration (**Additional Supplies**) allows to select additional supply source (for Loop and/or Sensor).

Figure 71: Creating new instrument - additional configuration page 1

Second page of the creating new instrument configuration data (**Other Error Limits**) helps to define additional error limits and possible messages about instrument adjusting needs.

Figure 72: Creating new instrument - additional configuration page 2

Add calibration and adjustment related notes with third page of the configuration (**Notes**).

Figure 73: Creating new instrument - additional configuration page 3

Fourth additional configuration page (**General**) shows different fields related to the amount of repeats, calibration interval and interval units.

Figure 74: Creating new instrument - additional configuration page 4

The last configuration page (**Device**) allows to input general data such as Location, Sensor Serial Number, Manufacturer and Model.

Figure 75: Creating new instrument - additional configuration page 5

To **delete** an instrument, select it and use the delete command available in the menu of opened [Instrument Overview Window](#).

Temperature Instrument Specifics

If you are creating an instrument where the input is temperature related, take note of the following specifics:

- If the input's **Quantity** is **Temperature**, i.e. you use the Temperature Block to generate the temperature, then the internal reference sensor is taken into use as a reference sensor.
- If the input's **Quantity** is **RTD Temperature** or **TC Temperature**, the input sensor is the reference. In this case a button for defining how the temperature is controlled becomes available (button label: **Automatic Control**). Additionally, if any external controllers are connected, they become available in the list of Controllers.
- For temperature quantities on instrument input and output, it is highly recommended to enable the **Additional Stability Check**, see section [Additional Stability Check](#).

Instrument List Window Menu

The Instrument List window's menu contains a lot of useful tools:

- **Create New** for creating a new Instrument etc. (See [Figure 76: Instrument List Window's menu](#))
- **Sort** for sorting the list contents alphabetically etc. Sorting icons shown in status bar (ascending / descending):



Identification



Due Date



Creation

- **Show** to display all or filter to a selected group of items in the list. The group can be, e.g. all calibrated instruments. When filtering is active, the following icon is shown in the status bar:
- **View Mode** for defining whether the **Plant Structure** or **Work Order** list is shown.
- **Browse** to jump to start/end of list or finding instruments. When find is in use, the following icon is shown in the status bar:
- **Manage** for deleting all Instruments/Results/Plant Structure levels and also for moving/renameing Plant Structure levels.

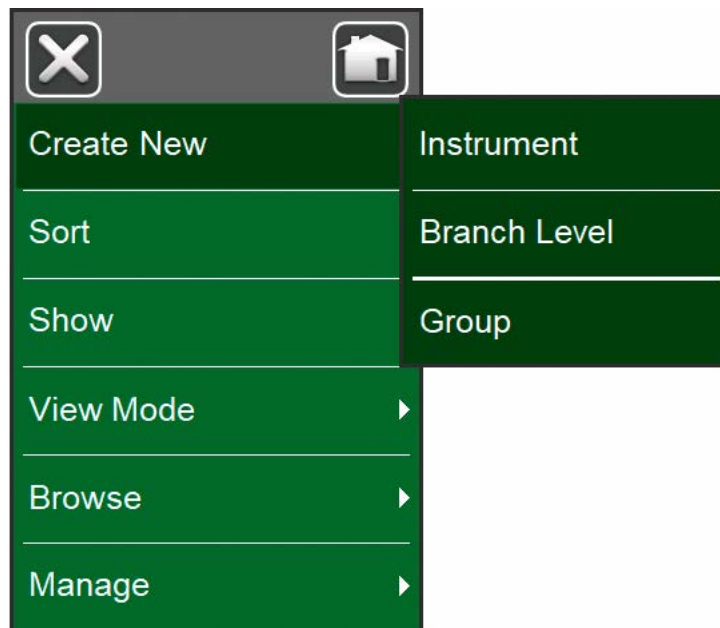

Figure 76: Instrument List Window's menu



Warning: Once an item is deleted, there is no way to retrieve it.

Plant Structure Levels

The name of the current Plant Structure Level is shown on the status bar. Tap on the bar to see the full Plant Structure path. Plant Structure Sublevels have yellow background and the upper right corner is folded. The Level's name is displayed and on the lower right corner, the amount of further Sublevels + the amount of instruments found on the next Sublevel.

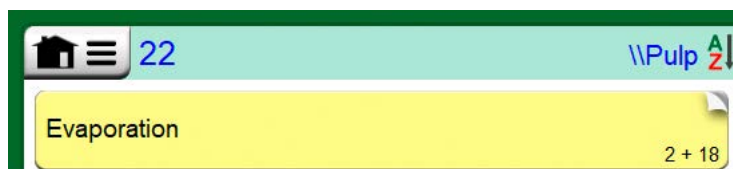

Figure 77: Current Plant Structure Level is called "Pulp". A total of 22 instruments are located on this Level and all its Sublevels. Sublevel "Evaporation" has two Sublevels and 18 instruments

To **select** a Plant Structure Level, tap on it. Then the contents of that level are displayed. To **return** to the previous level, tap on the "Back" button found on the right side of the Instrument List window.



Figure 78: "Back" button

Creating and managing **Plant Structure Levels** is presented in chapter [Instrument List Window Menu](#).



Note: Deleting a branch level also deletes all instruments and calibrations found on that level and all its sublevels. You cannot delete the structure root level.

Work Order View Mode

Work Order View Mode is an optional way of viewing the instruments. This option is of use, when instruments have been sent from Beamex CMX Calibration Software together with Work Orders in their Calibration Procedure. See [Figure 79: Activating Work Order View Mode](#) on how to activate Work Order View.

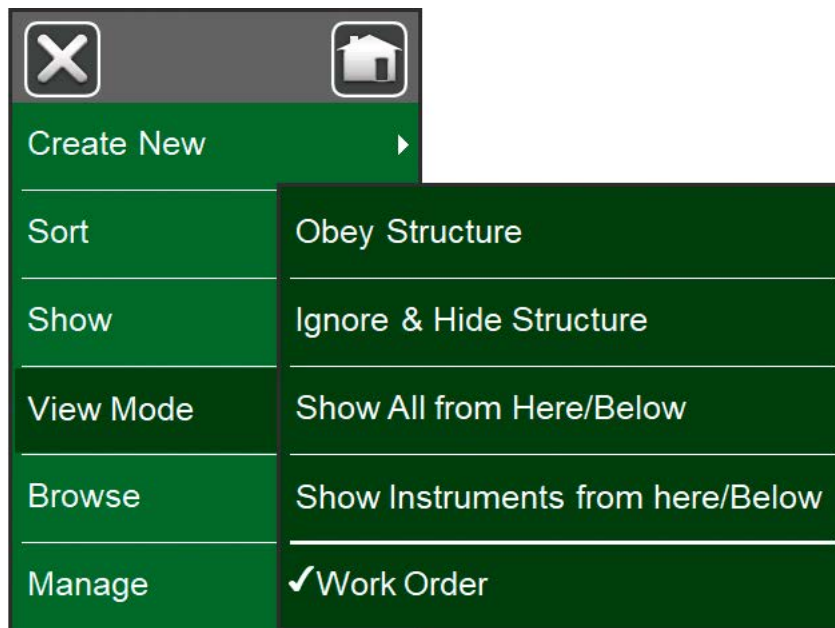

Figure 79: Activating Work Order View Mode

If Work Order View is active, a list of Work Orders are shown. Work Orders have green background, the upper right corner is folded and the left side has a blue line. The data in a Work Order are as follows:

- **Work Order Number** in upper left corner.
- **Start Date** and **End Date** below the Work Order Number.
- **Amount of Instruments** included in the Work Order are shown on the lower right corner.

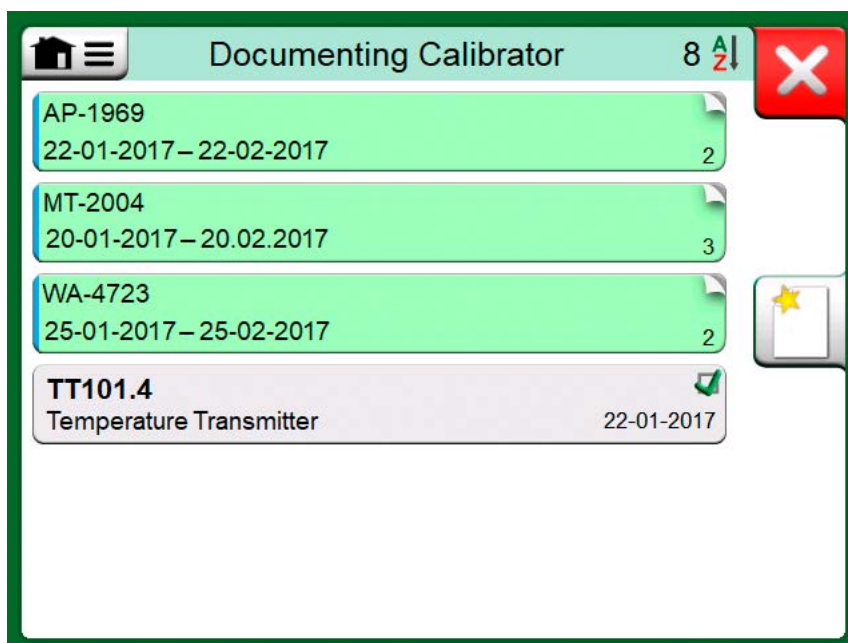

Figure 80: List of Work Orders

Any instruments not belonging to a Work Order are listed below the Work Orders.

Tapping on a Work Order opens a list of instruments belonging to that Work Order. To indicate that you are in Work Order View Mode, the instruments also have a blue line in their left side. Work Order's Start Date and End Date are presented in Instrument's lower right corner.

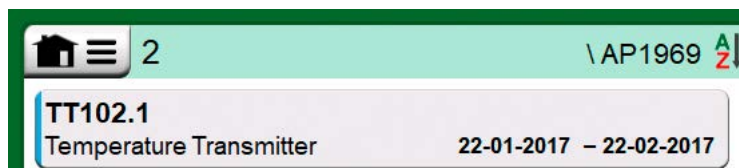

Figure 81: Instrument in Work Order View Mode

When a Work Order is selected, the menu allows you to delete the results of the current Work Order or delete the whole current Work Order.

Calibrating an instrument being part of a Work Order is done exactly as calibrating any other Instrument.



Note: In **Instrument Overview Window**, the possible Work Order is shown among Instrument's general data and on a separate page among instrument data. All basic data of Work Orders (Work Order Number and dates) are read only data in MC6-T.

When Work Order View Mode is active, Plant Structure is not shown and instruments may not be copied or moved within the structure.

Instrument Overview Window

When an instrument is selected, the **Instrument Overview** window opens and general data of the selected instrument is presented.

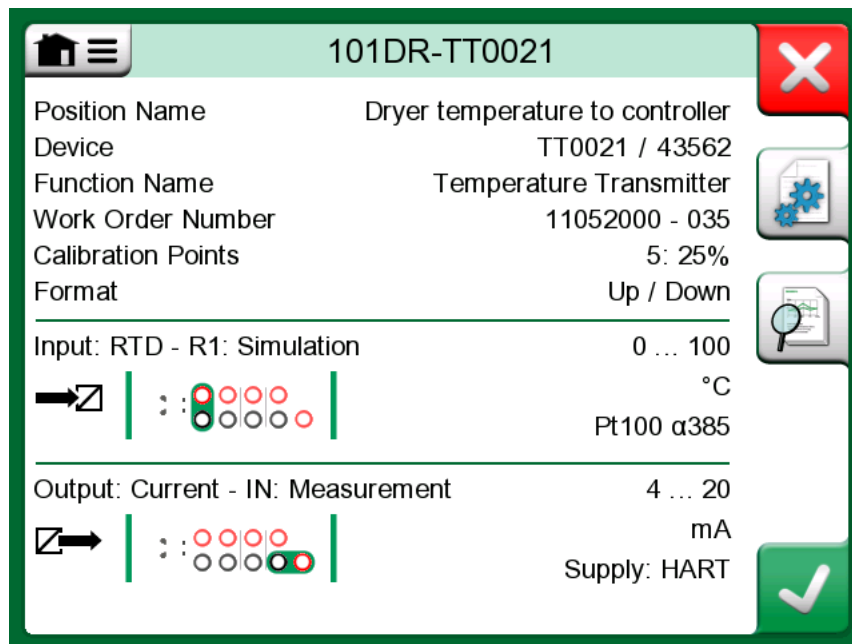





Figure 82: Instrument Overview Window

With the help of the buttons on the right side of the window, you may:

- cancel/return back to the instrument list () ,
- edit/check the instrument data () ,
- view calibration results () for this instrument (if applicable) or
- start calibrating the selected instrument and open the calibration window () .

Note that the menu contains some useful instrument related tools.

Calibrating an Instrument Using MC6-T

When you start calibrating an instrument, the **Calibration** window opens. See [Figure 83: Button for zeroing a pressure module \(lower right corner\)](#). Note that a possible **Before Calibration Note** window may open before the **Calibration** window is shown.

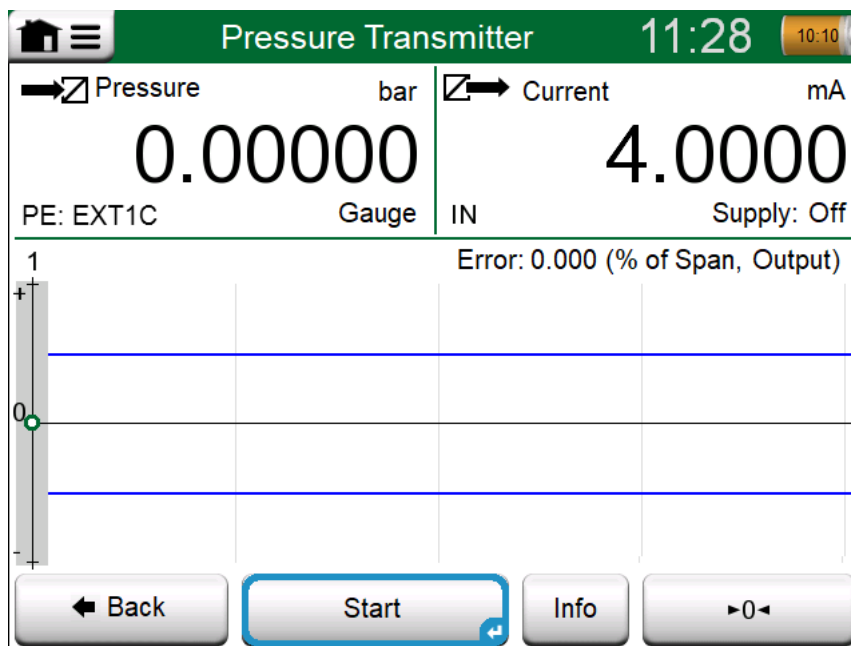

Figure 83: Button for zeroing a pressure module (lower right corner)

Before you tap the **Start** button, ensure that the signals are "live", i.e. measurements and the required connections are as they should. If unsure, use the connection diagrams found in the Instrument Overview Window. It opens from the **Info** button.

If gauge pressure modules are used in the calibration, remember to zero them before starting the calibration.

Tap the **Start** button to begin calibration. The rest depends on the instrument setting: **Automatic Acceptance**.

When **Automatic Acceptance** is in use (checked), MC6-T accepts calibration point automatically as follows:

1. MC6-T uses the **Max. Point Deviation** value to see if the input signal is close enough to the next calibration point.
2. When close enough, MC6-T checks the signal stability to decide whether the readings can be saved or not.
3. When signal stability is reached, a timer counts down as set in **Point Delay** and then the readings are saved only if the signal stability is still valid. See hourglass in [Figure 84: Calibration with Automatic Acceptance in use](#). If a signal becomes unstable, MC6-T returns to phase 2.

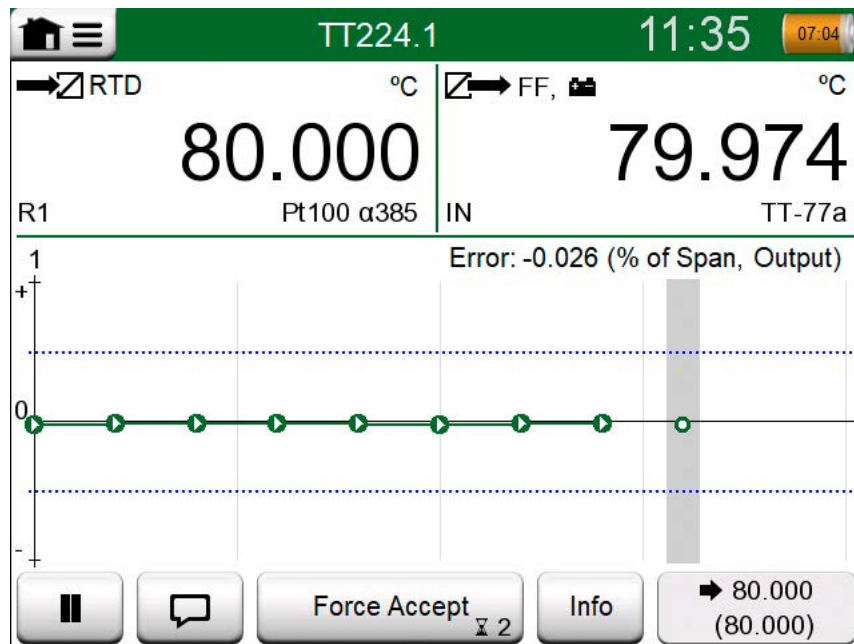

Figure 84: Calibration with Automatic Acceptance in use

Use the **Force Accept** button to manually accept points when, e.g. the calibration does not advance because of an unstable input and/or output signal.



Note: Opening the menu during calibration pauses the calibration for as long as the menu is open.

When **Automatic Acceptance** is not in use, every calibration point must be manually accepted by tapping the **Accept Point** button seen in the Calibration window. See [Figure 85: Calibration with manual acceptance](#).

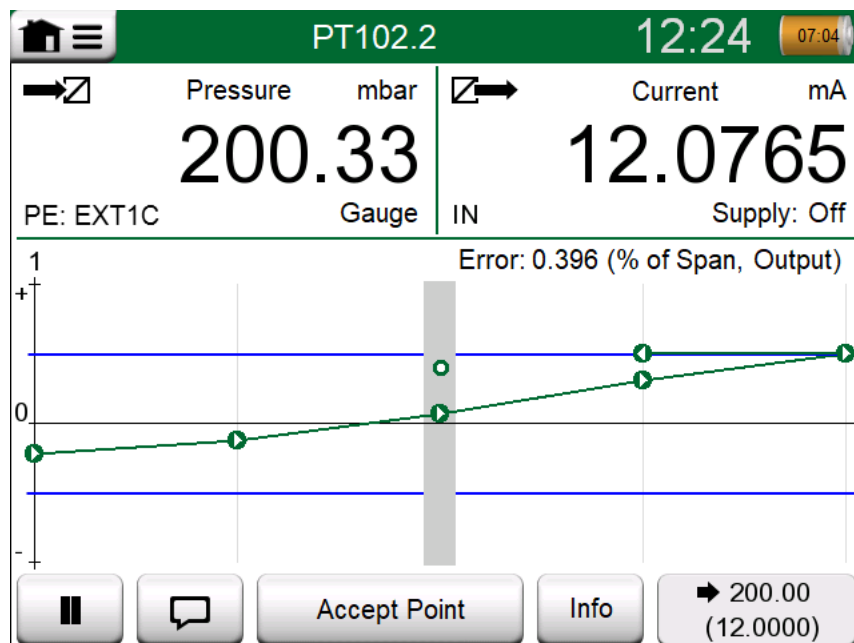





Figure 85: Calibration with manual acceptance

As the calibration advances, the graph is drawn from point to point. A grey column indicates where next target point is. The width of the grey column is based on **Max. Point Deviation** setting. Numeric values for the next target point can be seen in the lower right corner. If any of the points exceed the error limits (blue dotted lines), the graph is colored red.

The **Pause** button () allows you to reject a calibration or undo a point. The **Note** button () allows you to add notes to each calibration point. For further options, open the menu.

If you need to change the Pressure Module during the calibration, see chapter [Changing the Pressure Module During Calibration](#).



Note: Certain tools available in **Calibrator** are also available in **Documenting Calibrator**. To see the tools, open **Calibration** window menu, select either **Input** or **Output** and from the opened window, tap on the **Tools** button (). The available tools depend on the Quantity and Port selected for the input/output. The same tools are also available when editing the instrument data.

When the calibration is completed, the first of Calibration Result window's pages open telling you whether the calibration **Passed** or **Failed**. Browse through the pages to get an overview of the calibration results. Note that the amount of pages shown depends on the setting found in the window's menu. To see the basic pages only, open menu and select **Show, Basic Pages**. To see all pages open menu and select **Show, All Pages**.

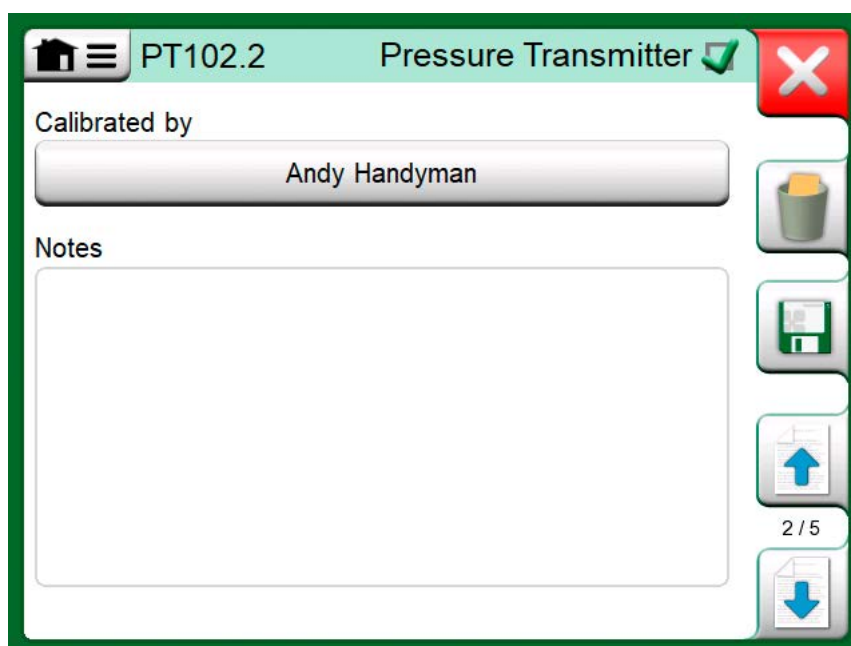

Figure 86: Calibration results page for entering calibrating technician's name, and possible notes

Input [mbar]	Output [mA]	Error [% of Span]	Significance [%]
0.00	3.9650	-0.2191	43.8
50.00	5.9725	-0.172	34.4
100.00	7.9800	-0.125	25.0
150.00	9.9950	-0.031	6.2
200.00	12.0100	0.062	12.5
250.00	14.0300	0.188	37.5
300.00	16.0500	0.313	62.5
350.00	18.0600	0.375	75.0
400.00	20.0700	0.438	87.5

Figure 87: Numeric calibration results page. For results including more than nine calibration points, use the scroll buttons or scroll bar to view hidden data

Save or delete the results using the buttons available on the right side of the window. When saving: In the following window: Tap on the **Combine with Previous Result** check box, if you want to combine the most recent result with previous results. When checked, calibration software treats all combined results as one calibration event containing several repeats.

After saving the results, you are brought back to the **Calibration** window where you may either start another calibration repeat or choose the **Back** button, to end calibration for this instrument.

Changing the Pressure Module During Calibration

If a calibration requires the use of several Pressure Modules, the Pressure Module has to be changed "on the fly". To do it, open **Calibration** window menu, select either **Input** or **Output** (depending on where the Pressure Module is connected). In the opened window:

- If the module to be used is internal or you are changing from an Internal Pressure Module to an already connected External Pressure Module, just tap the button below **Port/Function** text and select it from the available Pressure Modules.
- If you want to change the External Pressure module in use to another External Pressure Module connectable to the same port as the one currently in use, tap on the button seen in [Figure 88: Switching/ changing an external pressure module.](#) Continue with the change as explained on MC6-T's display.



Figure 88: Switching/changing an external pressure module.

About Fieldbus and HART Device Specifics

Detailed information of fieldbus and HART device specifics are discussed in chapter **Communicator**. However, here are some hints on where fieldbus and HART device related features appear in Documenting Calibrator.

Adding fieldbus and HART Instrument to MC6-T's database

When adding a fieldbus instrument or a HART instrument's digital output to MC6-T's database, select **HART**, **FOUNDATION Fieldbus H1** or **Profibus PA** as the output quantity. See [Figure 89: Documenting Calibrator's quantity selection window](#).

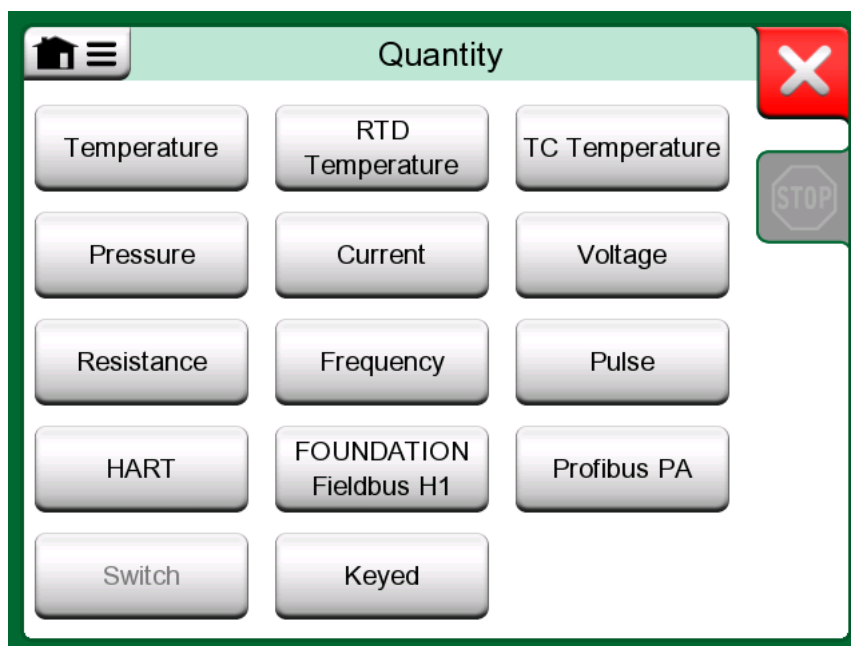

Figure 89: Documenting Calibrator's quantity selection window



Note: For HART instrument's **analog output**, select **Current** as the output quantity.

See also chapter [Get mapped value feature](#).

Additional utilities during calibration

During Calibration, MC6-T's menu has additional menu options available: For both HART and fieldbus instruments: a possibility to invoke the communicator to edit instrument data and when needed, start a HART trim

method. For fieldbus instruments, an additional menu option for trimming the instrument is also available.

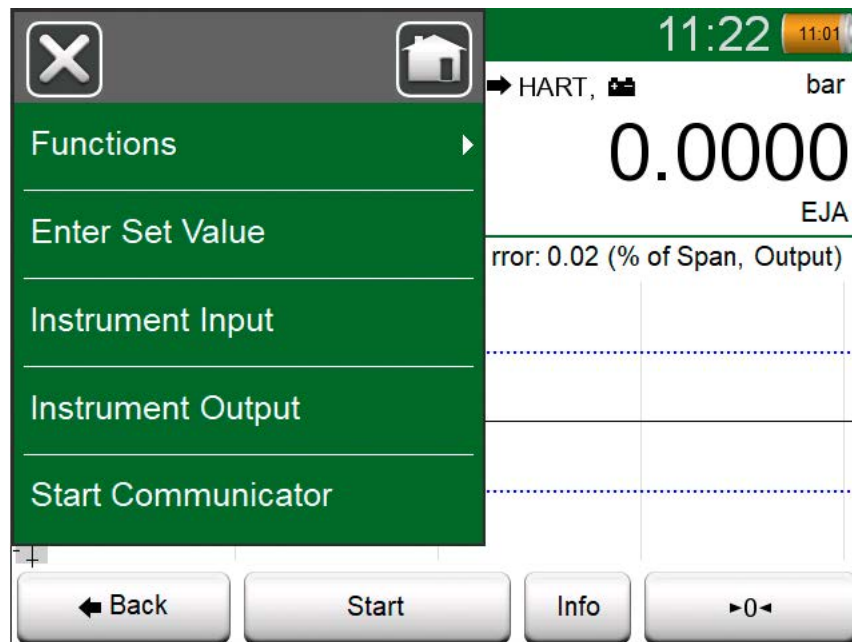

Figure 90: Menu in Documenting Calibrator when calibrating a HART instrument

Calibration Results

Once an instrument has been calibrated, you may view saved calibration results as follows:

- When viewing the **Instrument Overview Window**, select the **Calibration Results** button.

The most recent saved calibration is presented. If you want to see older results, open the menu in **Calibration Results** window and select **Results History**. Then a list presenting all saved results opens. See [Figure 91: Calibration results history window](#).

To separate calibration events from each other, they have a different shades of gray background colors. If the instrument's settings have changed, a field with blue background is seen. Tap it to see the settings as they were before that date/time.

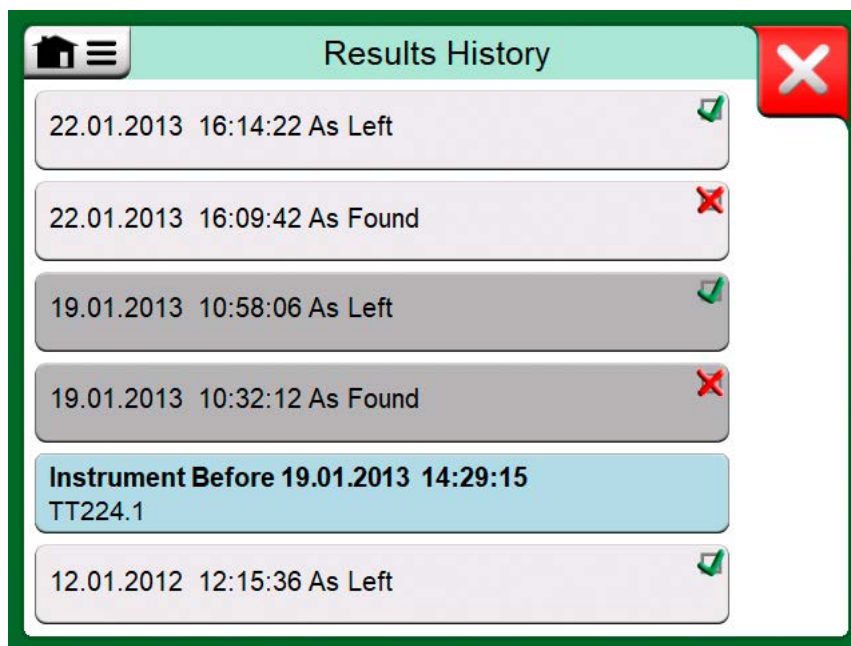

Figure 91: Calibration results history window



Note: Saved calibration results cannot be edited.

Deleting Calibration Results

When viewing the results of a calibration, you may delete the currently viewed result (menu option **Delete This Result**) or remove all results related to current instrument (menu option **Delete All Results**).

You may also remove all results related to current instrument in **Results History** window: Select menu option **Delete All Results**.



Warning: Once the results are deleted, there is no way to retrieve them.

Get mapped value feature

With the “Get mapped value” feature you can automatically read certain data from connected smart transmitter to the MC6-T instrument data. This automates process of creation of a new instrument to the MC6-T.

This is very useful especially with the long data fields, as they don't need to be added manually add to the MC6-T.

The selection of which transmitter's field is copied into which MC6-T field is configurable.

With this feature, you may add instrument data to MC6-T from Smart Instruments using Digital Communication:

- **HART®** instruments,
- **FOUNDATION Fieldbus H1™** instruments and
- **PROFIBUS PA™** Instruments

All you need is connect the instrument to MC6-T, select a communication protocol and receive data of the Instrument using Digital Communication to MC6-T's Instrument Data. No error prone manual entry of Instrument Data.

MC6-T has pre-entered default mappings (which Digital Communication Instrument field goes to which field in MC6-T) but you may customize the mapping for each instrument model you use.



Note: Utilizing this feature requires that your MC6-T has the option to communicate with the smart instrument type (Fieldbus option) you want to add to MC6-T's instrument data.

You may easily populate CMX's Instrument database by first mapping instrument data to MC6-T and then transferring the instruments to CMX.

More of Instrument's utilizing Digital Communication can be found in chapter [Communicator](#).

Getting and Editing Mapped Data

Preparations

The data mapping can be done to a new instrument or to an existing instrument in MC6-T. The Instrument's Output has to be one of the following:

- Current (measurement),
- HART®,
- FOUNDATION Fieldbus H1™ or
- Profibus PA™.



Note: With Current Measurement as the Instrument's Output, the communication is available for the HART transmitter found in address 0 only.

Getting Default Mappings

On any of the instrument data pages, open the menu and tap **Get Mapped Values**. Then MC6-T starts reading data from the connected instrument to MC6-T's Identification and Device fields, according to **Mapping** settings.

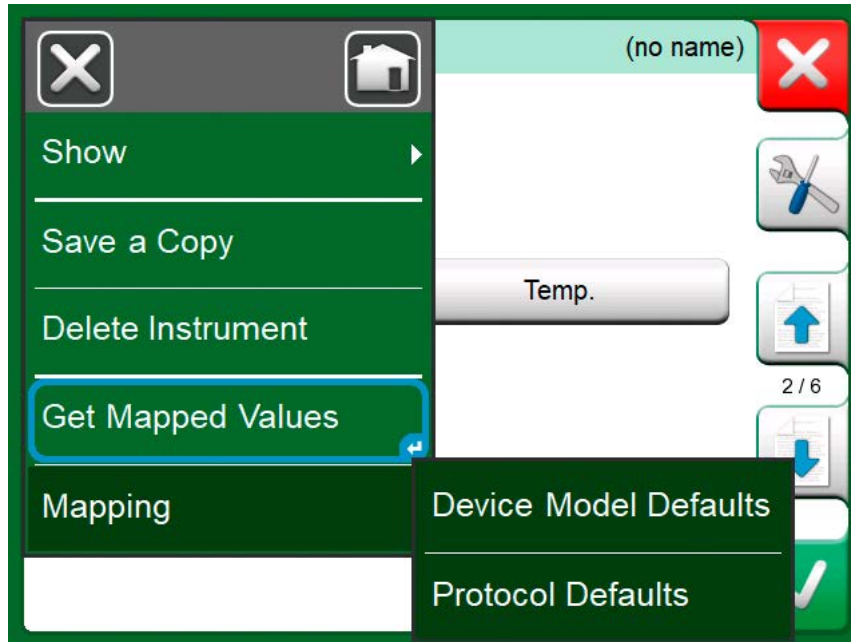

Figure 92: Mapping menus on instrument pages

That's all you need to do, provided the mappings suit your needs. If not, see chapter [Customizing the Mappings](#).

However, you should anyhow always check all the instrument settings after the data is read, before continuing with your work.



Note: For HART[®] Instrument's, the input setting is also read from the transmitter. For other instruments, you need to manually add the Instrument's input data.

Customizing the Mappings

The menu option, **Mapping**, has in its submenus options on how to define general mappings on protocol level (**HART**, **FOUNDATION Fieldbus H1** or **Profibus PA**) and also default mappings on device model level.

MC6-T uses the **Protocol Defaults** if no default mappings are defined for the connected device model. If **Device Model Defaults** exist for the connected device model, they are used instead of **Protocol Defaults**.

In the [Figure 93: Sample of default mappings for HART protocol](#) you can see a sample of the mappings. The left side lists the fields in MC6-T (target fields) and the Mapping Mode of the field (Generic in all cases of the sample picture). The right side lists the value and name of the field in the device.

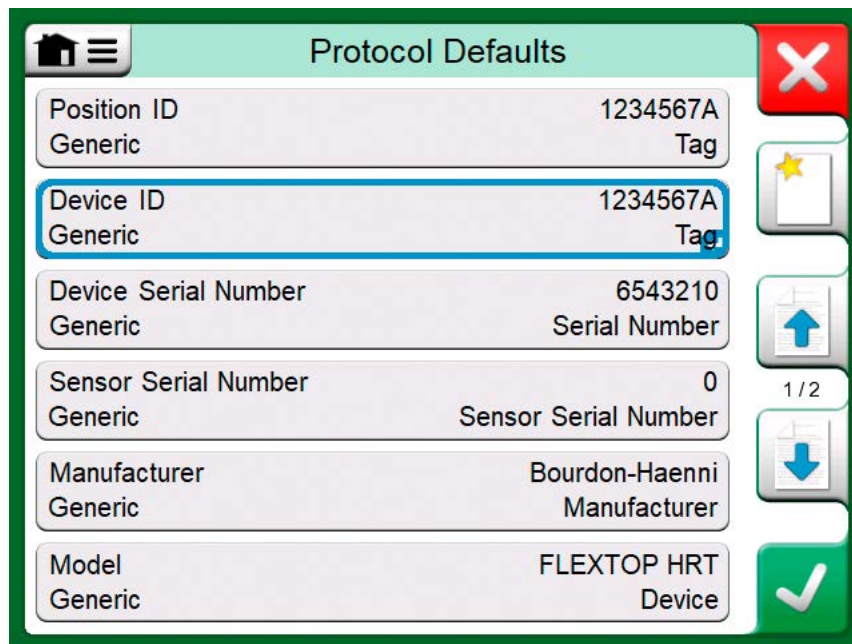



Figure 93: Sample of default mappings for HART protocol

Tap on one of the buttons to edit the mapping. You may also add new

mappings using the **New** button (). New mappings are defined similarly as existing mappings are edited.

Creating a new mapping or editing an existing mapping is done in a window like in [Figure 94: Sample of default mappings for HART protocol](#).

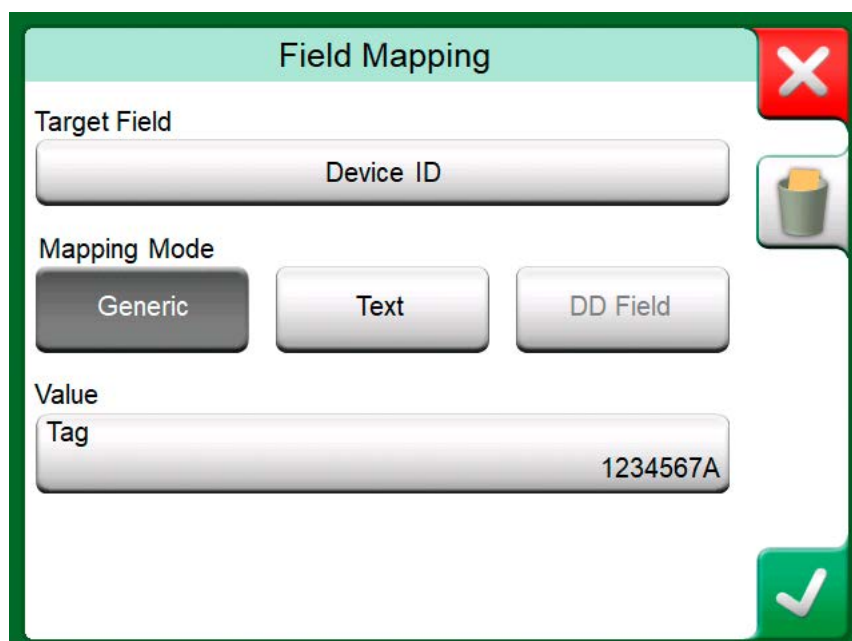

Figure 94: Sample of default mappings for HART protocol

Target Field is the field in MC6-T, **Value** is the field and its value in the connected device. Mapping Mode defines how the mapping is done.

- **Generic**, gives you a list of protocol's common fields.
- **Text**, assigns a fixed text to the selected MC6-T field.
- **DD Field**, gives you a list of all fields etc. available in the device model's Device Description. Note that this option is not available for the **Protocol Defaults**, only for **Device Model Defaults**.



Note: It is possible to map the same transmitter field into several MC6-T fields. In the [Figure 94: Sample of default mappings for HART protocol](#), device's **Tag** is mapped both to **Position ID** and **Device ID** in MC6-T's instrument data.

When adding or editing mapping, the target fields that are already being used are disabled (gray).

When you change the mapping, it will be saved as the default mapping for future use.

After changing the mapping, you need to read the data again using the **Get Mapped Data** menu command.

You can remove a single mapping line by opening it and touching the "Trash Can" icon.

Field	Value
Message	Tag
Range	-100...300(32)
Device ID Number	1014407
Tag (short)	ES22
Tag (long)	Elegant Stealth 22
Sensor Serial Number	32752A098

Figure 95: Generic Fields when Mapping Mode is "Generic"

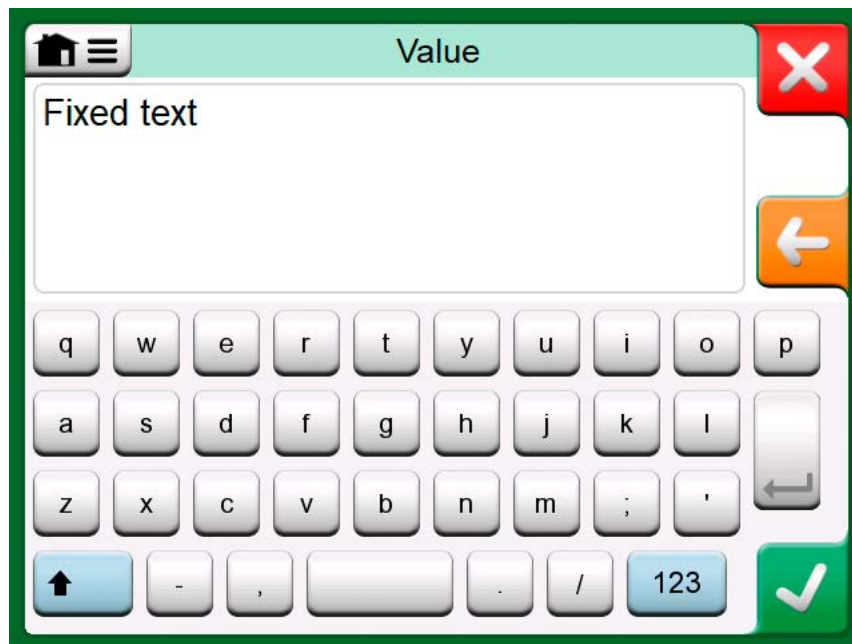

Figure 96: Text editing when Mapping Mode is "Text"

Mobile Security Plus software option

General

Beamex CMX Calibration Software version 2, revision 2.11 and later include an optional feature called **Mobile Security Plus**. It is a solution which ensures the integrity of calibration data throughout the Beamex ICS solution. It enforces security related settings in mobile devices. This solution requires Mobile Security Plus option to be enabled in both, CMX and in the calibrator. For detailed information about Mobile Security Plus functionality, please see **CMX User Guide**.

Applied Restrictions

The following Documenting Calibrator functionalities are either restricted with admin credentials or blocked, depending on the settings in **CMX**:

- **Skipping** or **undoing** a calibration point,
- **Rejecting** (exiting) an incomplete calibration without saving the results,
- Changing the **calibration date and time** of a keyed calibration,
- **Deleting** calibration results and
- **Deleting** an instrument with calibration results.

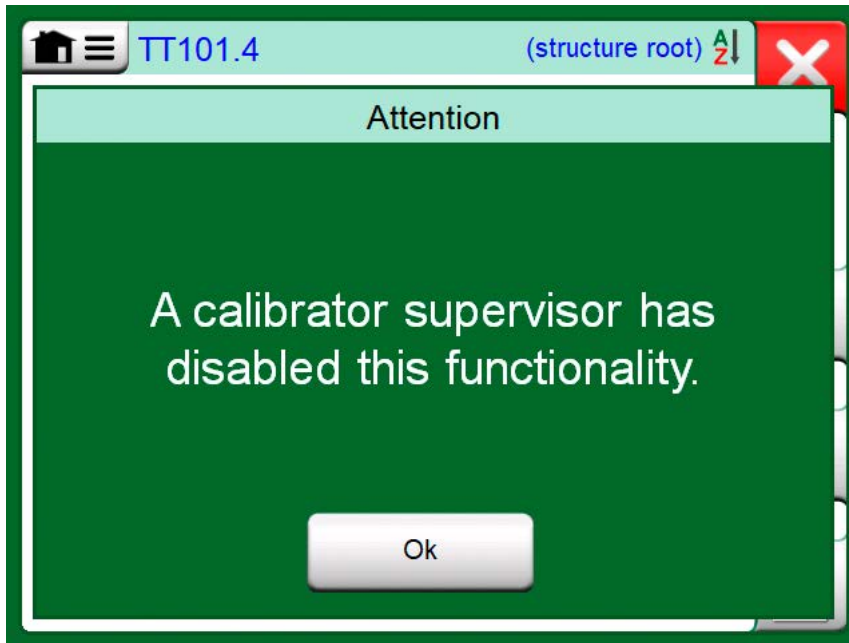

Figure 97: Calibrator's Message When a Functionality is Blocked

Additionally, Changing Regional Settings, Date and Time require admin credentials.

Data Logger

Things discussed in this part:

- An introduction to Data Logger option and its capabilities
- How to configure and start a Data Log
- How to view, save and delete Data Log results
- How to transfer Data Log results to a Personal Computer (PC).

General

The **Data Logger** is an optional operational mode that allows you to collect data with MC6-T. If the Data Logger option is purchased, the collected data may then be viewed, transferred to a Personal Computer (PC) and printed using a utility called **Beamex MC6 Data Log Viewer**.

Installation software for Beamex MC6 Data Log Viewer is downloadable from Beamex's web site <https://www.beamex.com>. Look for **Download Center**.



Figure 98: Home View with Data Logger selected

If your MC6-T does not have the option installed, the **Data Logger** icon in MC6-T's Home View is disabled.

If applicable, open the main configuration window of the Data Logger by tapping on the **Data Logger** icon in MC6-T's Home View (see [Figure 98: Home View with Data Logger selected](#)).

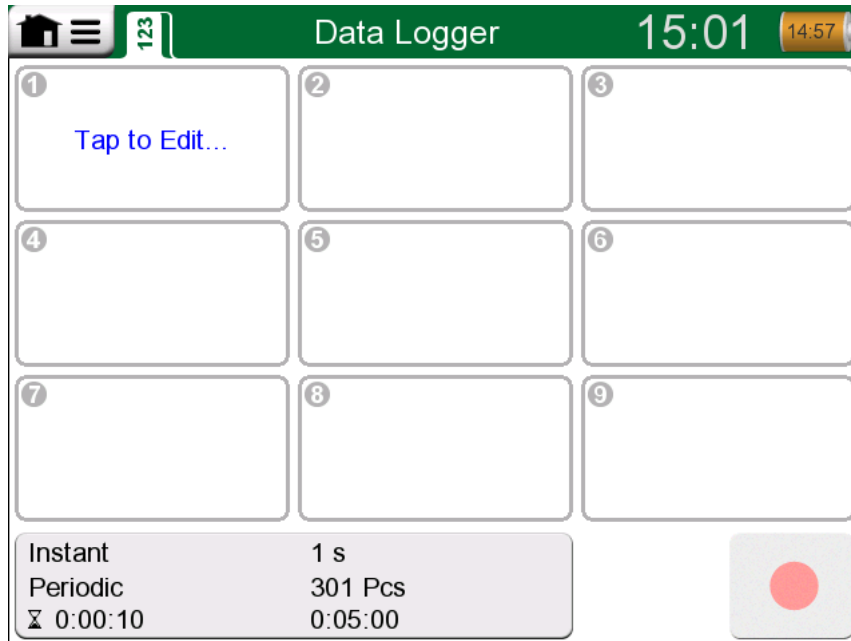

Figure 99: Main configuration window

Data Logger supports logging up to nine measurement/generation/simulation channels at the same time. However, the amount of available functions depends on how your MC6-T is equipped.

The [Figure 99: Main configuration window](#) is the **Data Logger**'s main configuration window when no data log channels have been configured. Typically, you see some previously configured channels, since MC6-T saves the latest data log configurations.

Doing a Data Log

Configuring

In the main configuration window: Tap on one of the numbered areas to configure a channel.

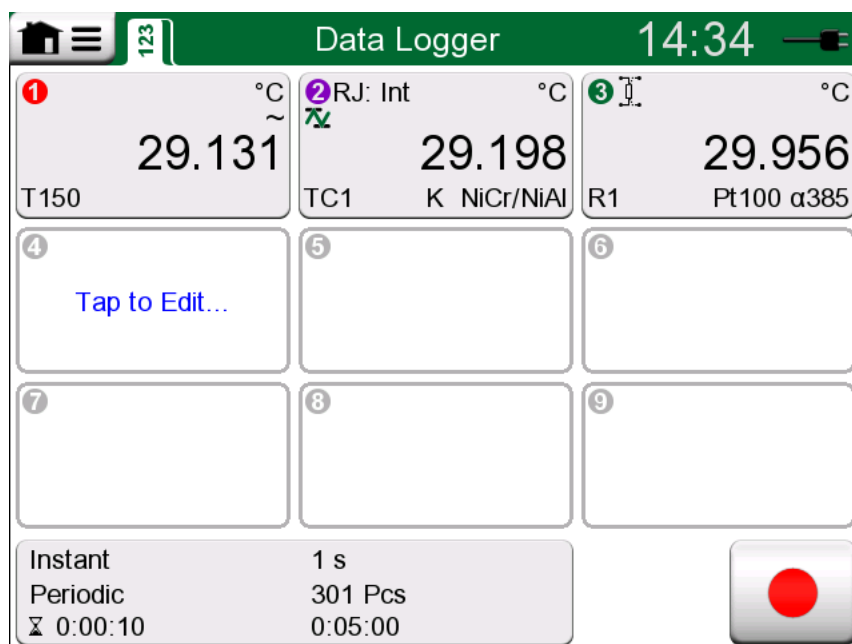

Figure 100: Three configured channels in main configuration window

Each channel have individual configuration pages as follows:

A page for defining the measured/generated/simulated quantity and its additional settings.

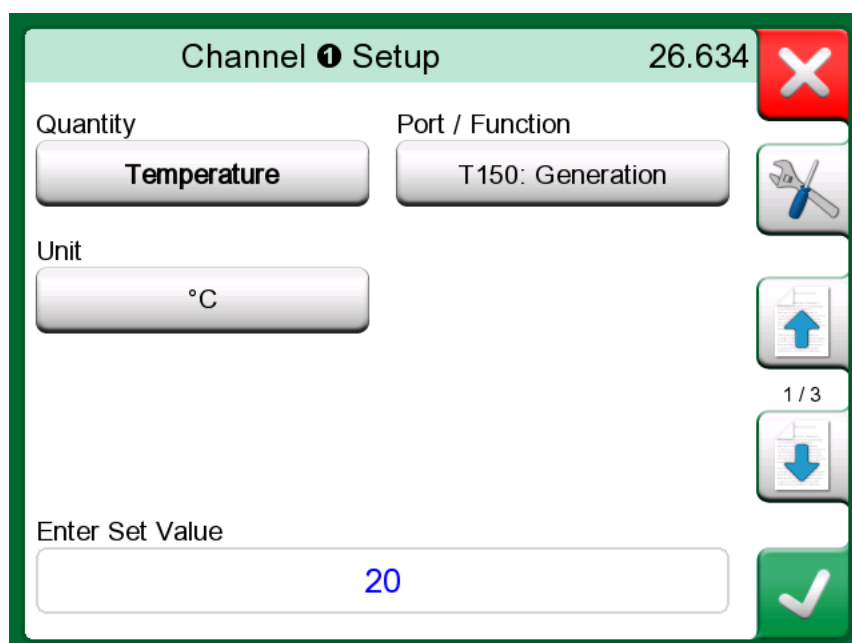

Figure 101: Data Log configuration window (for temperature generation) - 1st page

Second page for defining the range of the graph, giving the function a descriptive name (optional) and selecting plot color.

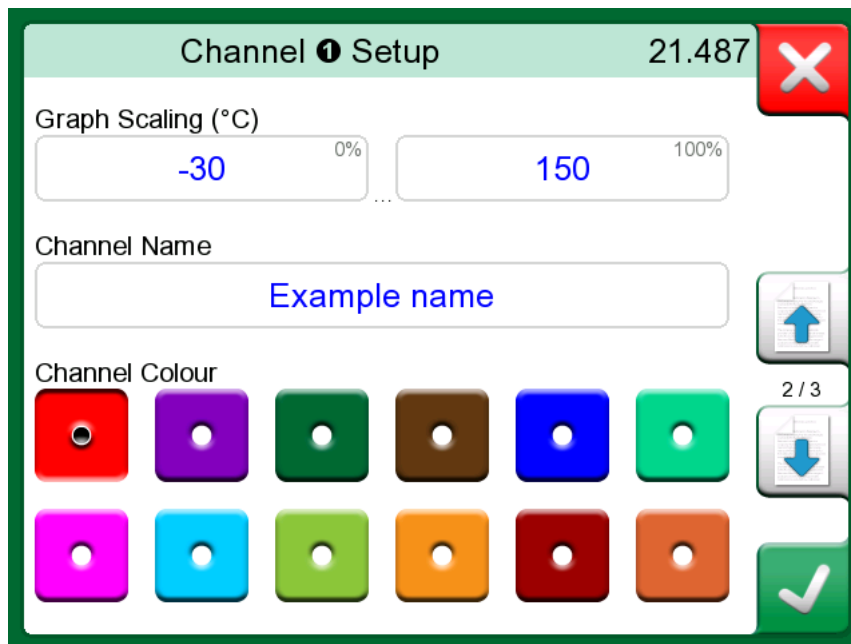

Figure 102: Data Log configuration window - 2nd page

A third page is available for measurement channels only: You may define a trigger that invokes the Data Log. When triggering is configured, a symbol indicates it. See [Figure 103: Data Log configuration window - 3rd page](#).

In this example, all four triggering methods are active. It is not necessary to use all four. When more than one trigger method is active, they are combined with logical *OR* function, i.e. as soon as one of them become TRUE, Data Logging will start.

As shown in [Figure 103: Data Log configuration window - 3rd page](#) example, Data Logging will start as soon as any of the following become true:

- The measured value is larger than 600
- The measured value is smaller than 45
- The rate of change of the measured value is larger than 20
- The rate of change of the measured value is less than -20

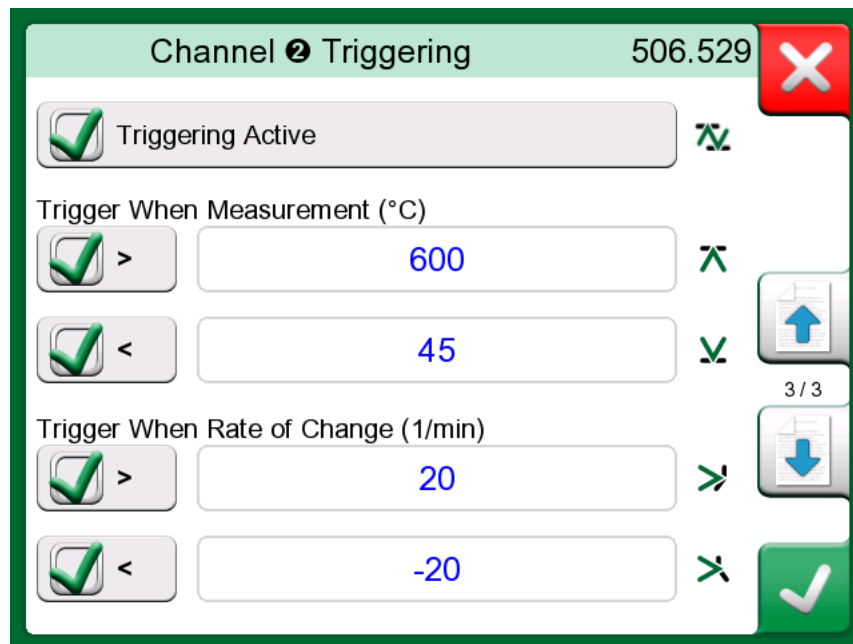

Figure 103: Data Log configuration window - 3rd page

Remember to check/edit the general settings of your Data Log. Tap on the area in the lower left corner of Data Logger's main configuration window, see [Figure 104: Data Logger, main configuration window general settings button](#). There you may, among other things, define how the logging is performed, what value is saved and the duration of the logging.

Instant	1 s
Periodic	301 Pcs
⌚ 0:00:10	0:05:00

Figure 104: Data Logger, main configuration window general settings button





Note: For pressure measurements:

The main configuration window's menu includes a possibility to zero gauge pressure modules. Zeroing is also possible in channel setup windows (when applicable).

Saving and Opening Configurations

In addition to MC6-T remembering the latest Data Log configurations, you may save useful configurations for future use. Saving and opening previously saved configurations is available in the menu of Data Logger's main configuration window.

Starting the Data Log

Start the Data Log by tapping on the **"Record"** button () in the main configuration window. The button changes to a **"Stop"** button () allowing you to interrupt your Data Log, when necessary.

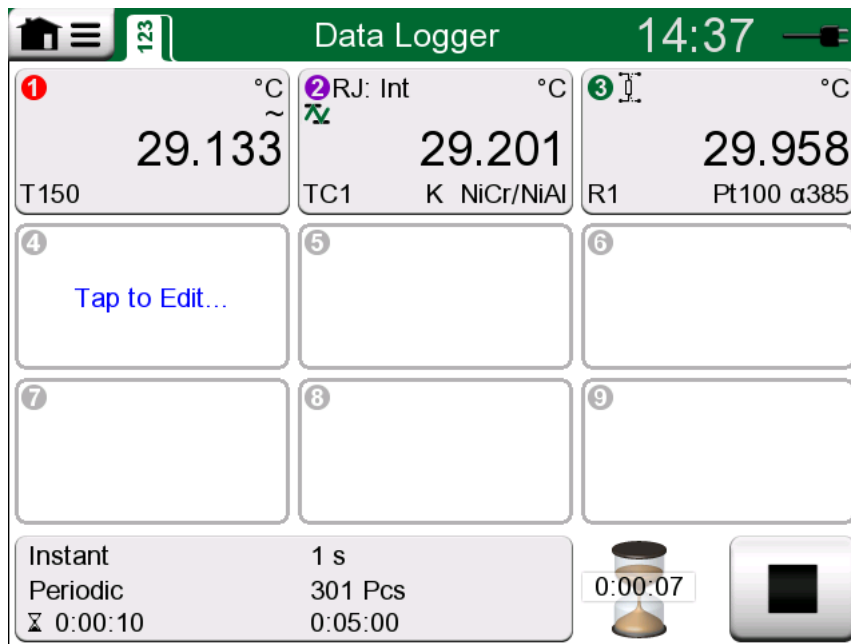

Figure 105: Counting down the delay

The actual start of Data Logging depends on general settings as follows:

- If you have defined a delay in the **Delayed Start** field, an hour glass with a down counter appears for as long as the delay requires. The delay may be either a defined wait time, e.g. 5 minutes, or a specific time of the day, e.g. 5:15 PM.
- If your **Logging Method** is **"Key Press"**, a camera button appears for you to take "snap shots" of the measurements.

When the possible delay defined in general settings has expired, possible triggers defined for individual channels delay the start of the Data Logging. Any channel that triggers, starts the Data Log.

You may change the view from the main configuration window to the graph view by tapping on the title bar. The active area is indicated in [Figure 106: Title bar's active area \(shown as yellow\) for toggling between main view and graph view.](#)



Figure 106: Title bar's active area (shown as yellow) for toggling between main view and graph view

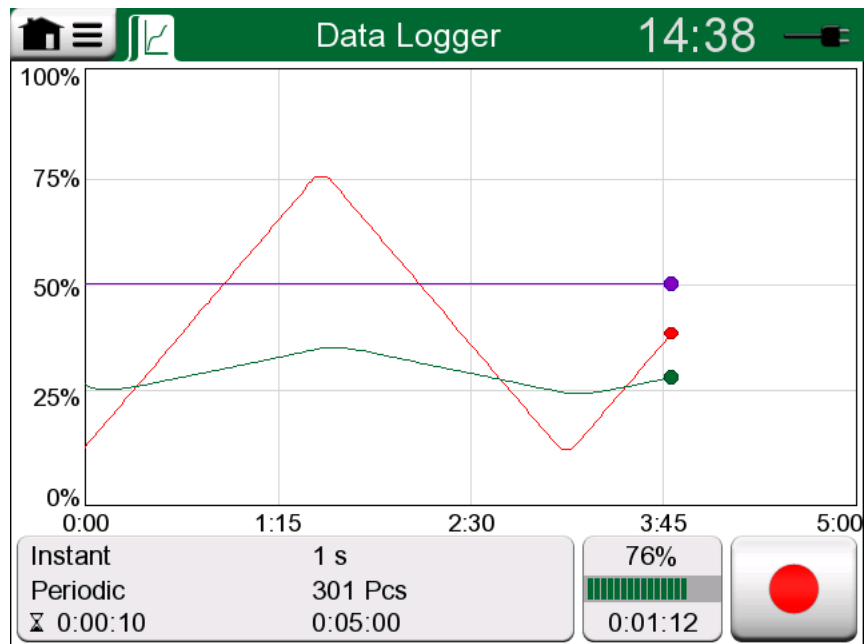

Figure 107: Graph view during Data Log



Note: If, in general settings, the **Logging Method** is "Key Press", none of possible triggers defined for individual channels are valid. The snap shot is saved immediately each time the

snap shot button () is tapped on.

A generation/simulation value may be changed during the data log as follows:

In the main configuration window, tap on the channel where a generation/simulation is configured. In the opened window, locate the output value field and tap on it to edit the numeric value.

Viewing and Saving or Deleting the Results

When Data Logging is finished, or stopped, the results are shown on three pages: general information page, graph page and a table of numeric results. If the table of numeric results is large, use the scroll buttons or the scroll bar to see hidden rows/columns.

Results Preview			
Time	OUT (V)	P1 (mbar)	TC1 (°C)
25.11.2013 14:14:12	Instant	Instant	Instant
14:14:58	9.19420~	26.295	187.97~
14:14:59	9.32233~	26.295	189.54~
14:15:00	9.57961~	26.294	190.83~
14:15:01	9.77181~	26.295	192.66~
14:15:02	9.96403~	26.297	194.09~
14:15:03	10.1562~	26.294	195.65~
14:15:04	10.3484~	26.295	197.16~
14:15:05	10.5406~	26.295	198.84~
14:15:06	10.7328~	26.295	200.57~

Figure 108: Results Preview

All pages include a possibility to either save or delete the Data Logging results.

When saving, you have the possibility to give a descriptive name to the Data Logging results. MC6-T automatically adds date and time to the Data Logging results.

Viewing Saved Data Log Results

If you have saved Data Logs, they may be viewed as follows:

- From the menu of the Data Logging's main configuration window. Select menu option **View Data Log Results**.

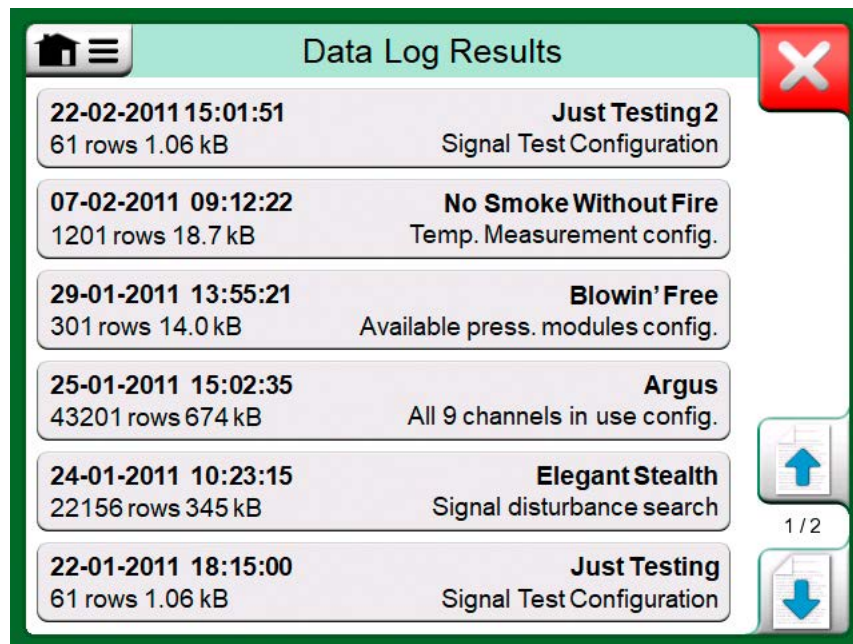

Figure 109: Data Log Result list

Each saved Data Log result has the time/date it was saved and the entered result name on the first row in bold font. On the second row you can see information of Data Log's size and possibly the name of the configuration used for doing the Data Log.



Note: When viewing the list of saved Data Log results, the menu includes the possibility to **Delete All** saved Data Log results. If you select one of the existing results for viewing, the menu includes a possibility to either **Delete** or **Rename** the viewed Data Log results.

Transferring Data Log Results to a Personal Computer

Beamex MC6 Data Log Viewer (executable file: "MC6DataLogViewer.exe") reads data log results to a Personal Computer. The software works in any 32 bit or 64 bit Windows system, starting from Windows[®] 8. Installation software for **Beamex MC6 Data Log Viewer** is downloadable from Beamex's web site <https://www.beamex.com>. Look for **Download Center**.

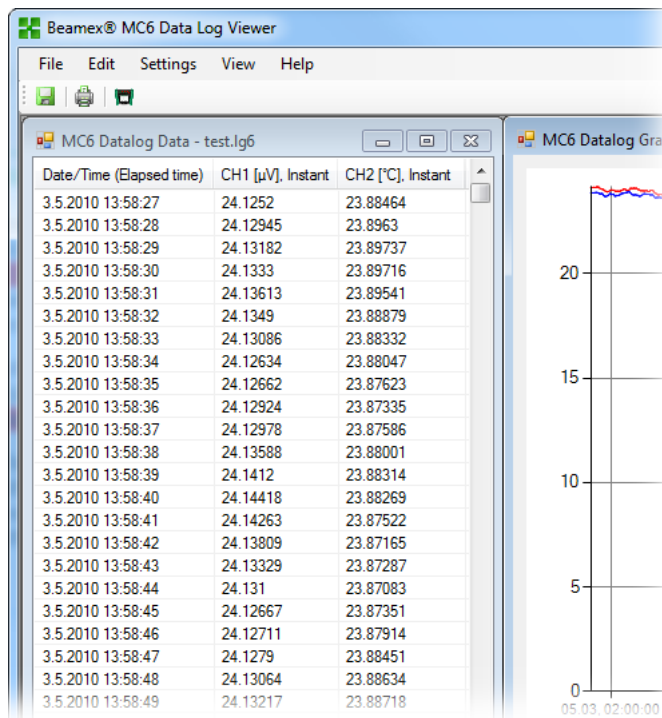

Figure 110: Screenshot of Beamex MC6 Data Log Viewer

Before you read data from MC6-T, you must connect MC6-T to your PC using the USB cable provided. Then install the driver as presented in [General description](#), chapter [USB Communication Driver](#).

After the driver is installed, the software can be used for downloading the results from MC6-T and viewing the results. The data can be saved in the application's native format (.LG6) or saved as **CSV** files. The latter format can easily be imported into spreadsheet software.

Communicator

Things discussed in this part:

- An introduction to the MC6-T's Communicator and how it can be started
- How to connect to smart instruments capable of digital communication
- Instructions on how to quickly select a variable/parameter for use in Calibrator, Documenting Calibrator or Data Logger
- How to edit instrument parameters
- How to trim a Fieldbus/HART instrument.

General



Figure 111: Home View with Communicator selected

MC6-T's **Communicator** option is an optional tool that allows you to connect to instruments, communicating with one of following Digital Communication protocols:

- **HART**[®] instruments (HART Protocols 5, 6 and 7)
(<https://www.fieldcommgroup.org/>)

MC6-T can be used as a primary or secondary master.

- **FOUNDATION Fieldbus H1**[™] instruments
(<http://www.fieldbus.org/>)

MC6-T is seen as a guest device (visitor) and, when necessary, as a Link Active Scheduler (LAS, segment's master device).

- **PROFIBUS PA**[™] instruments
(<https://www.profibus.com/>)

MC6-T takes the role of PROFIBUS Master when connected to a PROFIBUS segment.

When **Communicator** is started, a list of communication protocols available for MC6-T is shown. See [Figure 112: Communication protocols](#).

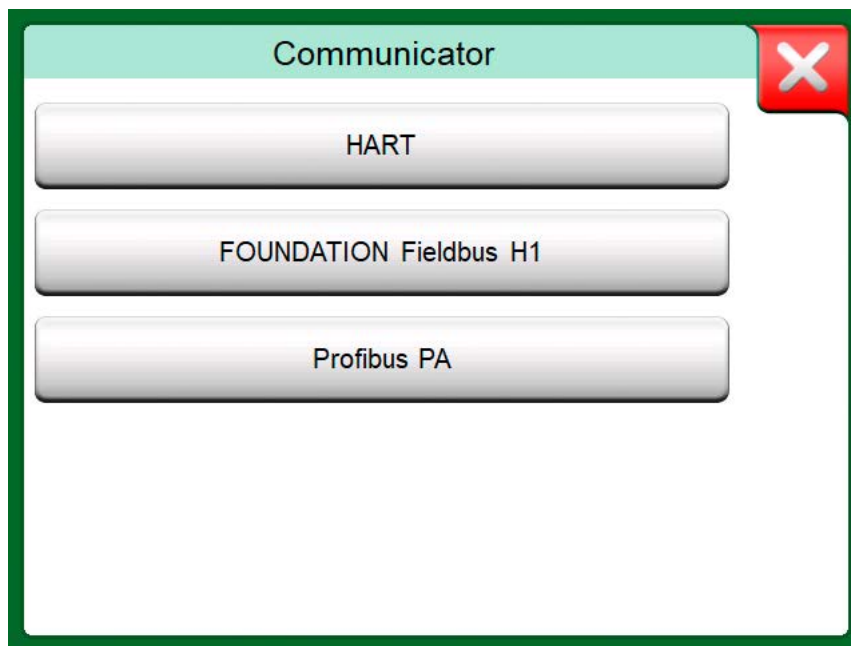

Figure 112: Communication protocols



Note: Each communication protocol is a separate option in MC6-T, therefore all protocols are not necessarily enabled in your MC6-T.

This manual is not an introduction to HART and Fieldbus instruments. Get the know-how and terminology from books dedicated to HART and Fieldbus instruments and technology.

The Communicator's user interface may include text in another language than what MC6-T's user interface language setting is. This happens when the language of the instrument's fields etc. differ from MC6-T's.

Communication may also be started from the following main functions in MC6-T:

- **Calibrator**,
- **Documenting Calibrator** and
- **Data Logger**

Depending on active/inactive options, some communication protocols may be disabled (grayed).

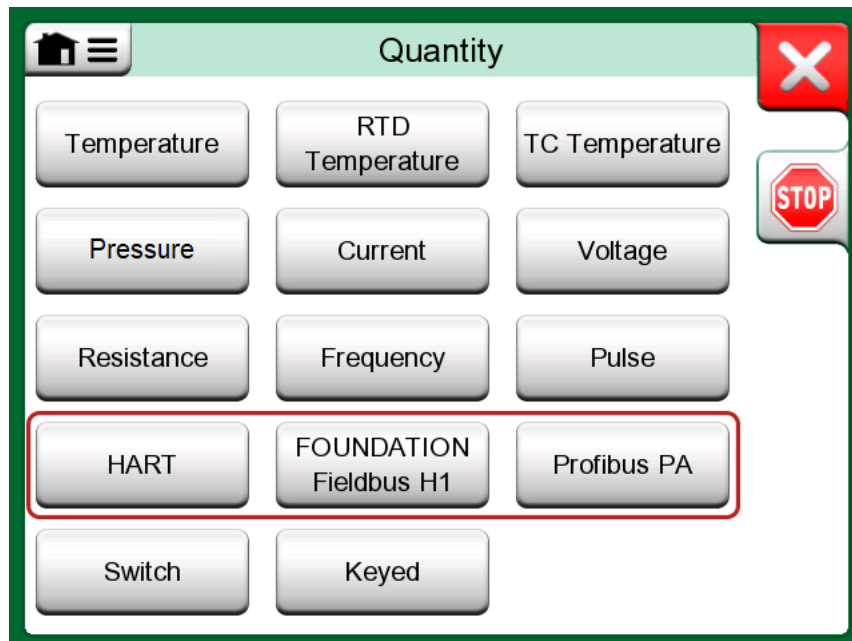

Figure 113: Selecting a communication protocol in Calibrator, Documenting Calibrator and Data Logger

MC6-T's **Communicator** is primarily meant for viewing and editing the configuration of Digital Communication Instruments. However, when invoking communication from **Calibrator**, **Documenting Calibrator** or **Data Logger**, you most likely plan to **select a Variable or Parameter** (e.g. Primary Value) for calibration or data logging instead of doing full configuration for the instrument. MC6-T, of course, supports this functionality too.

See also chapter [HART Device Description Specifics](#).

Warnings



Warning: Configuring/calibrating an instrument that is part of a live segment is possible in HART and FOUNDATION Fieldbus. When working in a live segment, first make sure, the control loop the instrument is part of is set to manual. Follow the guidelines available in the instrument's own manual.

Beamex cannot be held responsible for any damages caused by connecting MC6-T to a live factory fieldbus segment.



Warning: Using MC6-T to change the parameters of an instrument may result in discrepancies: A fieldbus host control system may mirror all instrument parameters in its permanent database. In such a case, when returning an instrument with changed parameters to a live segment, ensure that the parameters are also available in the control system's permanent database. Also verify that the new parameters do not result in an unstable control loop.

Connections

When communicating with Digital Communication Instruments, the connection differs depending on whether MC6-T's internal power supply is used or not.

The [Figure 114: Using MC6-T's internal power supply](#) presents the connections when **MC6-T's internal power supply is used**. MC6-T's power supply can safely provide supply power to a single instrument. If connecting to a HART/fieldbus segment containing several instruments, consider using an external power supply as presented further on.

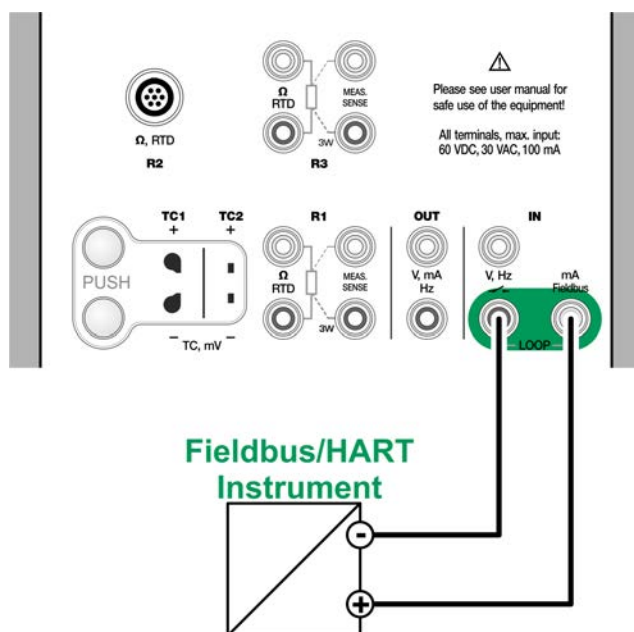

Figure 114: Using MC6-T's internal power supply

The **Figure 115: Using an external power supply** presents the connections when **an external power supply is used**. Then, to ensure communication, there may be need to include an external resistor (250 ohm for HART and 50 ohm for fieldbuses). However, when using a fieldbus compliant power supply, there is no need for an external resistor.

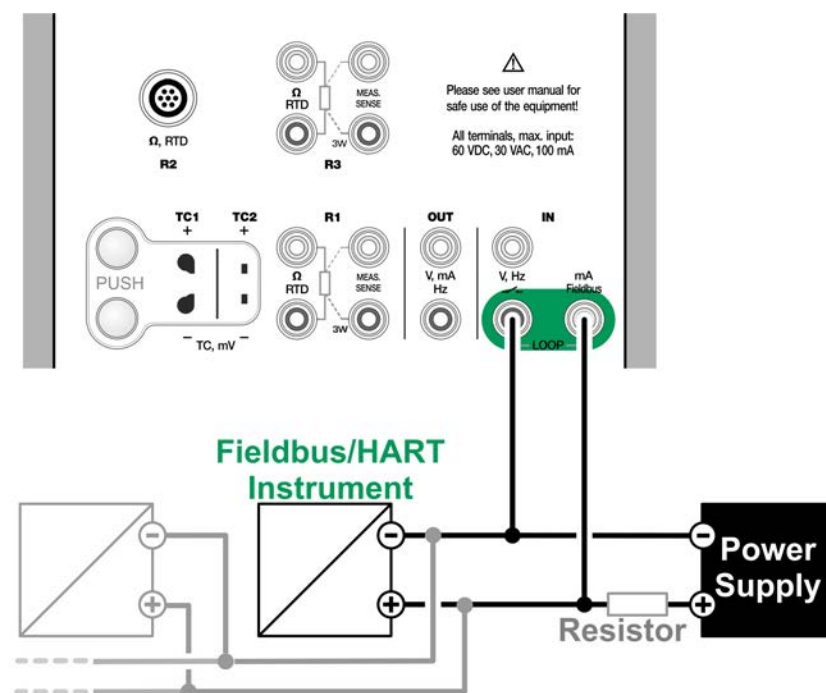



Figure 115: Using an external power supply

Note: The connection between MC6-T and the instrument/fieldbus may be done using a pair of standard measurement cables. However, when using longer connecting cables there may be need for fieldbus terminators.

See also chapter [HART Device Description Specifics](#).

List of Found Devices

When continuing, MC6-T searches (monitors) for connected instruments and a window with a list of devices found opens. The window also includes

a "refresh" button () to retry the search for connected instruments.

The "settings" button () allows you to quickly edit the tag and address for the listed instruments. When edit mode is on, the button backgrounds change to blue.

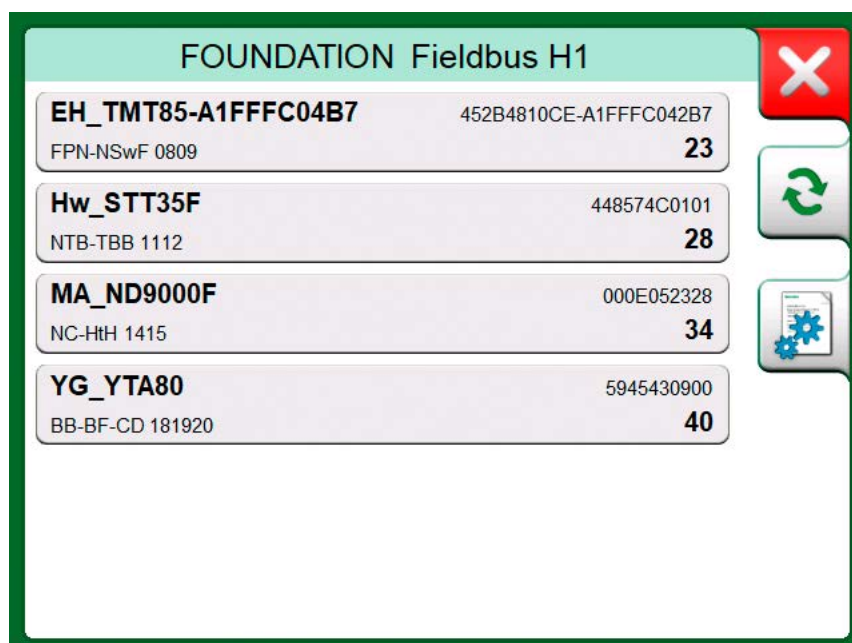

Figure 117: A list of devices found

When not editing tag and address, select the instrument for calibration by tapping on its name in the displayed list. Then MC6-T uploads the instrument's data into its memory and when ready, displays it.



Note: If MC6-T does not have the Device Description file for the selected instrument, a window opens informing you of the situation. Look for new Device Description files at Beamex's website: <https://www.beamex.com>. Install a downloaded Device Description file using the Device Description Installer software available at Beamex's website: <https://www.beamex.com>. Look for **Download Center**.



Warning: When the calibrator is monitoring a fieldbus/HART segment, DO NOT disconnect/reconnect the calibrator to/from the segment. The segment may become unstable.

About Instrument Parameters

Instrument Parameters in General

This chapter briefly presents how **Blocks**, **Records** and **Parameters** of Digital Communication Instruments are viewed in MC6-T and how you may browse through them. Elements seen while viewing/configuring an instrument:

- **Blocks** and **Records** have yellow background where the upper right corner is folded. They may contain sub-blocks, sub-records, editable parameters and read-only parameters. Tap on the block/record to see its contents.
- Different types of **Parameters**:
 - **Editable Parameters** have gray background. They may be numeric, text, single select, multi select or date fields. Tap to edit the field data.
 - **Read-Only Parameters** are data that you may view/read but they cannot be edited. They have gray background with a "lock" in the upper right corner.
 - **Value Parameter** is actually a special case of the Read-Only Parameter. The value is a result of a measurement and cannot be edited, but it can be opened for viewing and selected for use in the **Temperature Calibrator**, **Calibrator**, **Documenting Calibrator** or **Data Logger**. Value Parameters have green background. See also note to the right and hint below
 - **Methods** look like parameters, but are actually automated procedures for e.g. calibration in HART instruments. For details, see instrument's user manual.

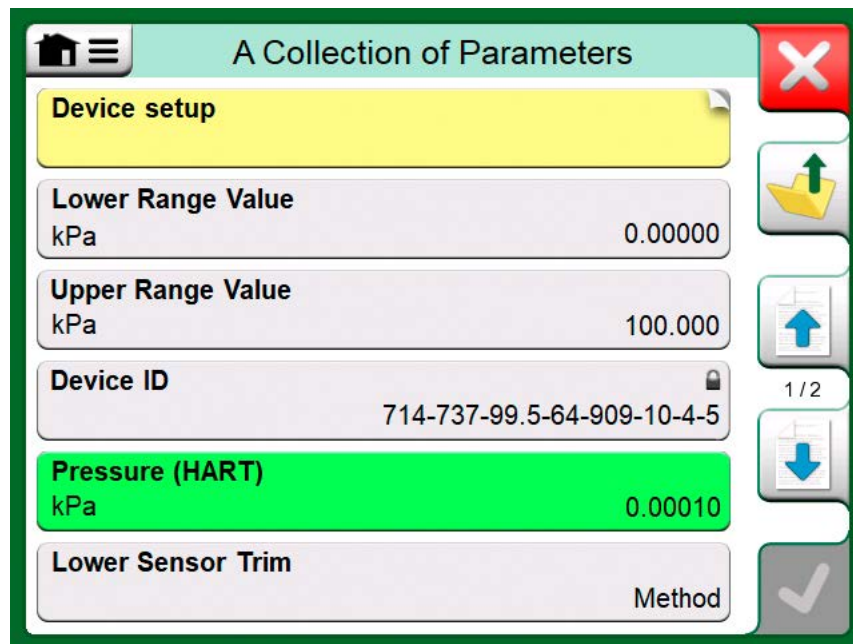

Figure 118: Blocks and Parameters, an example view



Note: Since value parameters are often of high interest, the menu contains a possibility to view value parameters (measurable variables) only.

See also chapter [HART Device Description Specifics](#).



Note: If you select a Value Parameter and you started communication from the **Communicator**, the value is taken into use in **Calibrator**. If communication is started from any other supported operational modes, e.g. **Data Logger**, the chosen Value Parameter is taken into use in that particular operational mode.

Calibrating or Data Logging HART Instruments

Usually, when calibrating or logging, you need to locate a **Value Parameter**, a Process Variable, in the HART's instrument data. Remember that Value Parameters have green background.

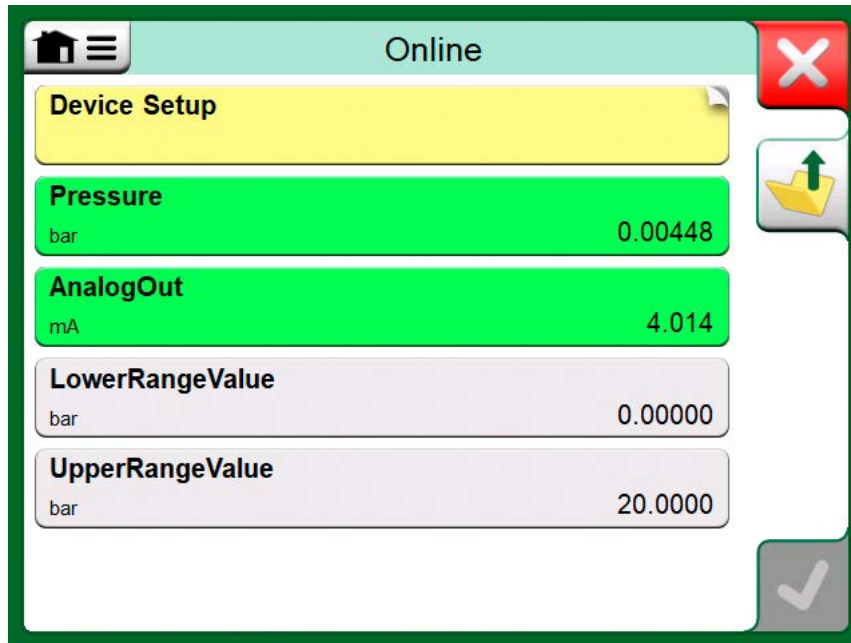

Figure 119: Example of a variable list in a HART Transmitter

Unfortunately the structure of data and naming conventions in HART instruments vary between different makes and models. Thus there is no single path from selecting the instrument in MC6-T to locating the parameter.



Note: Go to **Menu, Show, Measurable Variables** for easy way to find parameters.

Refer to your instrument's manual to find the blocks where the parameters are located.

Once the parameter is located, tap on it. In the opened window: Tap the **Accept** button to start calibrating or logging that parameter.

Calibrating or Data Logging Fieldbus Instruments

This is a quick guide for selecting a **FOUNDATION Fieldbus** or **Profibus PA instrument's Parameter** for calibration/data logging. If you want to make more extensive configurations, refer to chapter [About Instrument Parameters](#) and the manual of your instrument at hand.

1. First you must select either **FOUNDATION Fieldbus** or **Profibus PA** as your communication protocol and select the instrument as presented in chapter [Selecting the Instrument](#).
2. **Transducer** is the typical name of the **Block** (folder) where measurement parameters are located. When applicable, tap on it. Note that the **Block** name depends on the instrument, so when uncertain, refer to your instrument's user manual.

3. Browse the opened list of blocks, records and parameters. Tap the one you select for use in MC6-T, e.g. **Primary Value**.
4. Accept the selection by tapping on the **Accept** button.

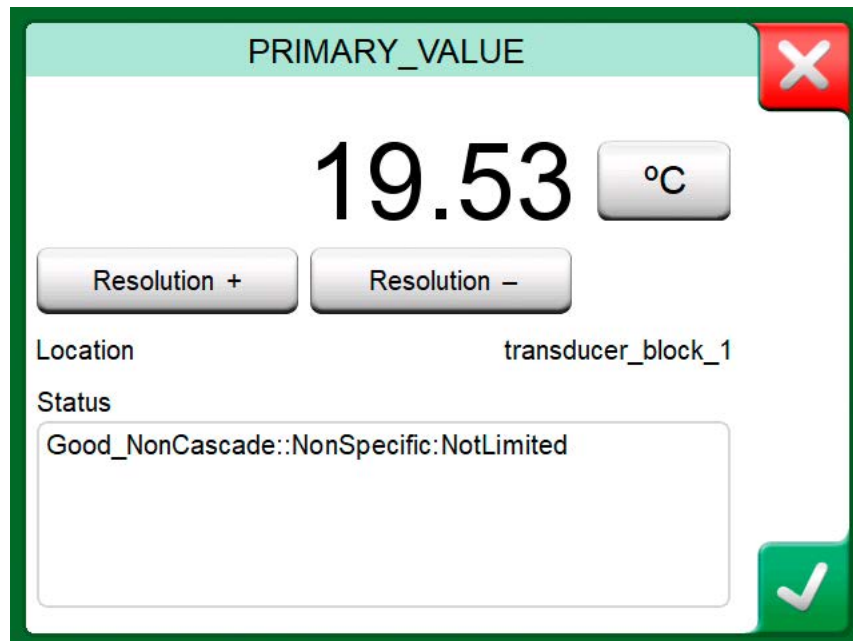

Figure 120: Accepting a parameter

Editing Parameters

With "editing parameters" we mean changing any editable parameter in the instrument's memory, e.g. selecting the type of process connection fitted to the instrument.

Editing a Parameter is started by tapping on it. A window opens for editing the data. The type of window depends on the type of parameter that is edited, e.g. a selection list, text or a numeric value.

When editing a stand-alone parameter (stand-alone in this context means it is not part of a record that contains several parameters), the edited value is sent to the instrument immediately when the accept button is tapped on.

In a **HART** instrument: If a parameter is part of a **record**, i.e. several parameters together as in the example [Figure 121: Example of a record: Sensor Information](#), each parameter may be edited separately. However, the edited values are not sent to the instrument until the accept button of the record window is tapped on. Prior to sending, edited parameters have a blue background.

Sensor Information	
Isolator Material	316L
Fill Fluid	Silicone Oil
Gasket Material	316L
Process Connection Size	1/2NPT Male
Process Connection Material	316 SST
Process Connection Type	Conventional

Figure 121: Example of a record: Sensor Information

See also chapter [Warnings](#).



Note: This manual explains how the parameters are accessed using MC6-T. For detailed information of instrument data, refer to the manual of the instrument itself.

Beamex cannot be held responsible for any damages caused by changing instrument parameters.

Trimming a HART Instrument

Trimming a **HART** instrument can be started from the **Documenting Calibrator's** menu and also from other MC6-T's operational modes where HART communication may be started. When calibrating a HART instrument, the Documenting Calibrator's menu contains the option **Start Communicator**, see [Figure 122: Documenting Calibrator menu with HART instrument connected](#).

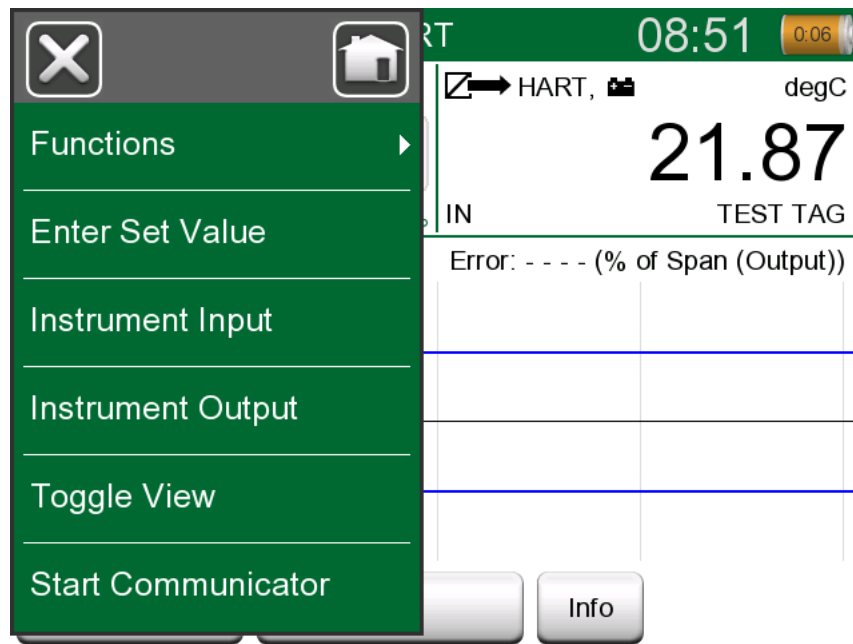

Figure 122: Documenting Calibrator menu with HART instrument connected

When trimming, refer to the instrument's user manual to locate and start a trimming method, either for the analog or the digital signal / sensor. When the method is located follow its instructions. At some point during the method, you need to apply an applicable input signal. See [Figure 123: Sensor trim method](#).

- If the trimming procedure was invoked from Documenting Calibrator, the lower part of the window has areas where the instrument's input (1) and possibly also the output (2) readings are shown. Use the input signal area to check what the correct reading is.
- If the trimming procedure was invoked from another MC6-T main function, e.g. Communicator, tap on either of the areas reserved for calibrator readings and select a suitable Quantity for measurement.

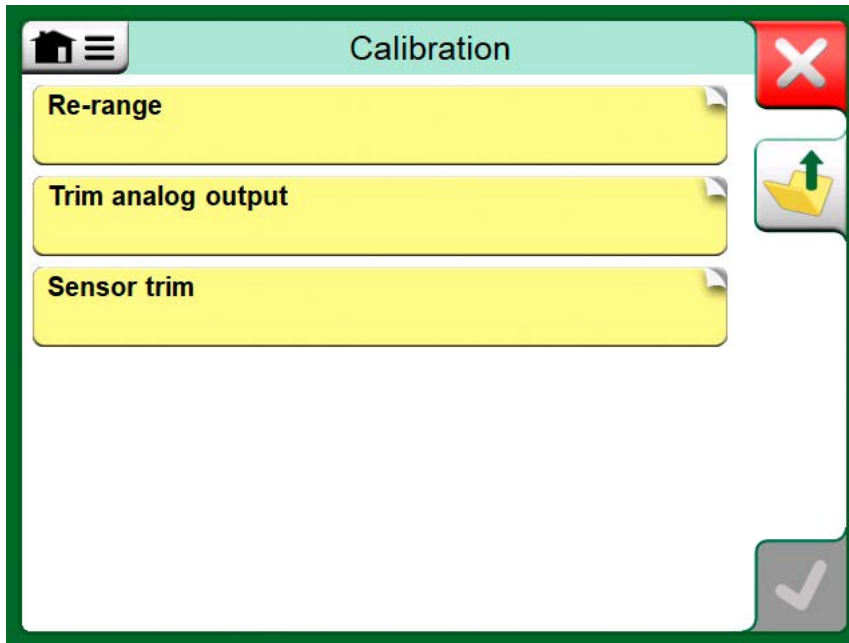



Figure 123: Sensor trim method

In both cases: When the input signal is as required, enter the correct value to the numeric field that is made available at this stage. Optionally, use

one of the **Copy** buttons () to copy the reading available in the areas reserved for calibrator readings.

To finalize the trim, continue as the trim method describes on MC6-T's display.

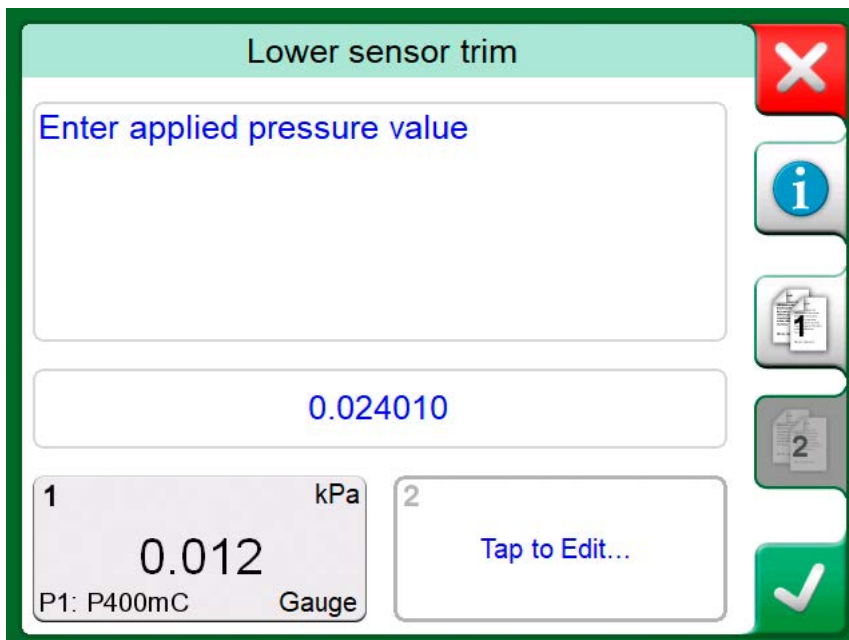

Figure 124: Trim method in progress



Note: Just as in fieldbus instruments, the user interface and manuals of HART instruments are sometimes using the misleading term "calibration" although it is actually a trim that is performed.

Be careful during the trimming procedure. Follow the instructions in the instrument's user manual. Skipping a step in the procedure may result in an unsuccessful trim.

Typically, the correct order for trimming is: digital output first, then analog output.

Trimming a Fieldbus Instrument

Trimming a **FOUNDATION Fieldbus** or a **Profibus PA** instrument can be initiated from the **Documenting Calibrator**, provided the relevant communicator option is enabled and the instrument's Device Description contains information of parameters needed for trimming.

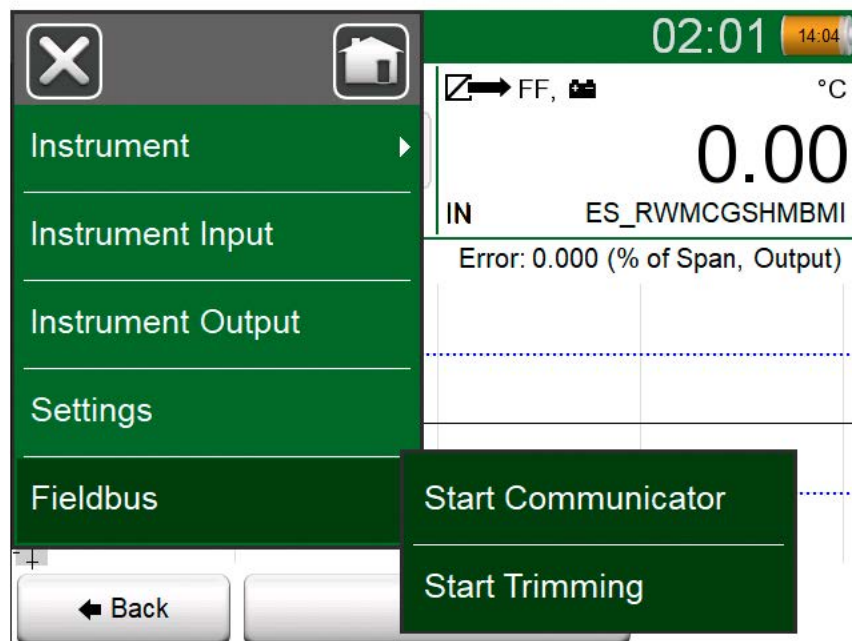

Figure 125: Menu in Documenting Calibrator when calibrating a fieldbus instrument

Menu option **Start Trimming** opens a window similar to the [Figure 126: Fieldbus instrument's trimming window, example](#). The list of Blocks and Parameters depends on instrument's Device Description. The lower part of the window has areas where the instrument's input (1) and output (2) readings are shown.

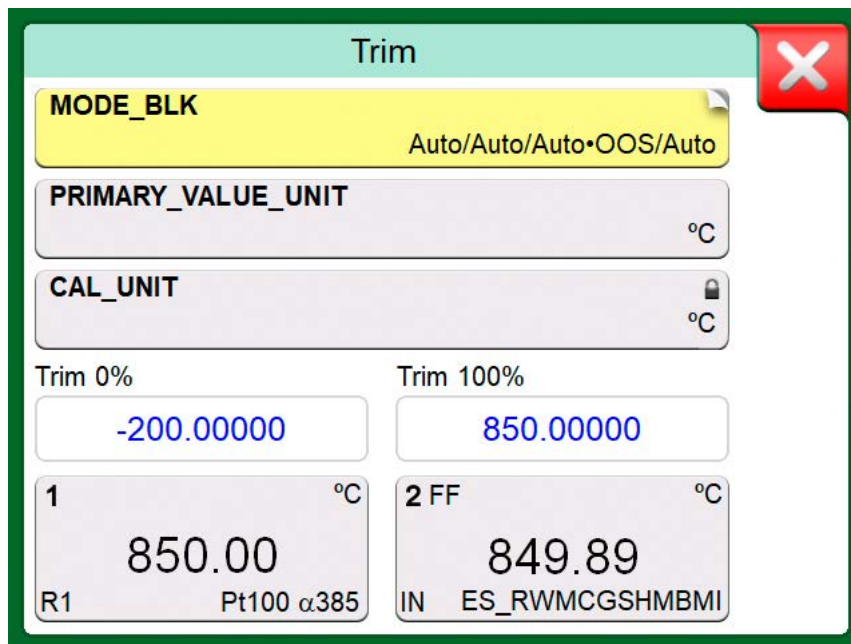

Figure 126: Fieldbus instrument's trimming window, example

Refer to the instrument's user manual for detailed information on how the trim procedure progresses. Usually you first set the **Mode Block** to OOS (Out Of Service) and then start editing the other data.

The actual trim is done by tapping on **Trim 0 %** or **Trim 100 %** values after a valid input signal is generated/simulated/measured. A window for editing the numeric value opens. The window includes a button for copying the input reading as the correct value.



Figure 127: Copy button



Note: Some fieldbus instrument manuals and user interfaces use the term "calibration" when they actually mean a trimming procedure. Be aware of this pitfall when trimming a fieldbus instrument.

Be careful during the trimming procedure. Follow the instructions in the instrument's user manual. Skipping a step in the procedure may result in an unsuccessful trim.

HART Device Description Specifics

About HART Device Description

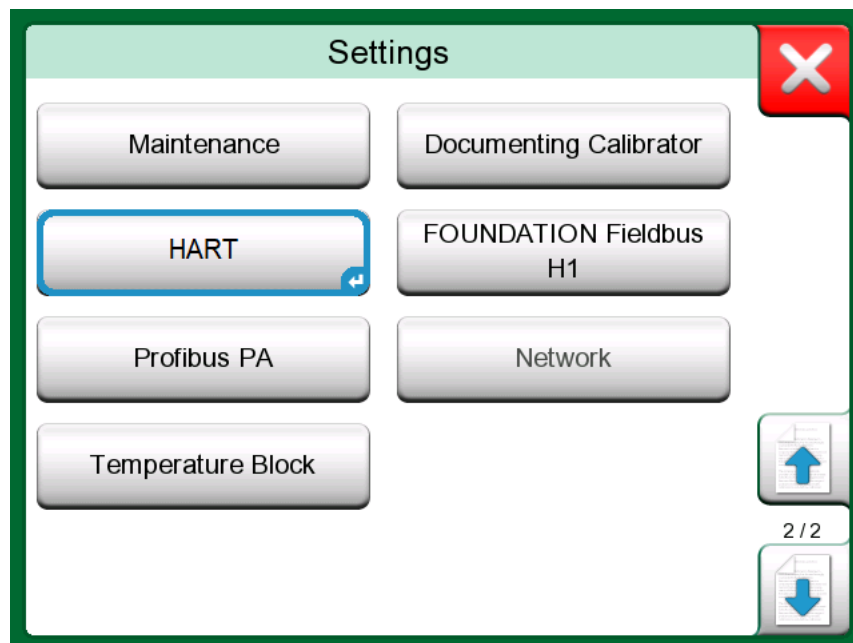

Figure 128: HART in MC6-T's Settings

MC6-T supports the use of three kinds of Device Descriptions for HART instruments:

- **Device Specific**, i.e. custom Device Descriptions for the HART device at hand, available in MC6-T. Full instrument data is available.
- **Generic**, i.e. a library of common Device Descriptions applying to most HART devices. Only a standard set of instrument data is available.
- **Basic View**, a simplified Device Description available in MC6-T. It presents the instrument's value parameters only in addition to basic Device Setup and Process Variable Settings.

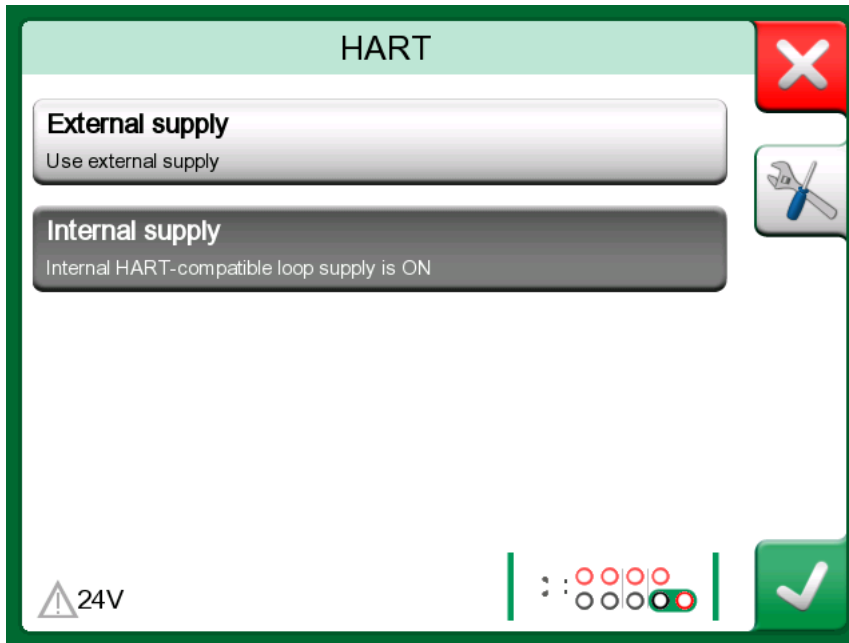

Figure 129: HART Tools elsewhere

The default setting of Active Device Descriptions in MC6-T may be defined in **MC6-T's Settings**. Also: When connecting to a HART device and selecting the supply, the tools button on the right opens HART settings where you can select the Active Device Descriptions (see [Figure 129: HART Tools elsewhere](#)). This is available in **Calibrator**, **Documenting Calibrator**, **Data Logger** and **Communicator**.

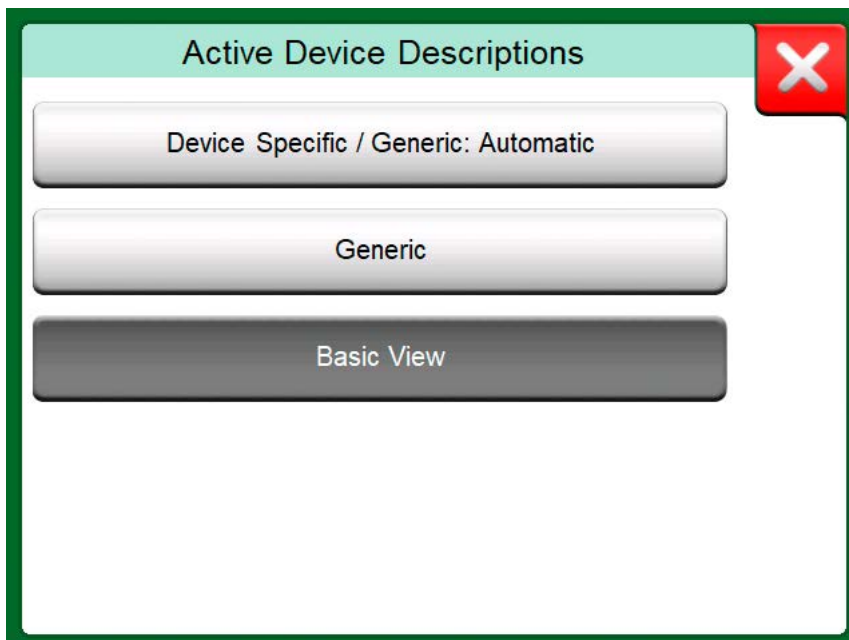

Figure 130: Window for Selecting a Device Description for Use

Basic View

MC6-T's Basic View simplifies the use of HART instruments, since all that is seen are the instrument's value parameters in addition to basic Device

Setup and Process Variable Settings. Select any value parameter you like for calibration, data logging etc.

Variable	Value
AO mA	20.500000
PV °C	323.305237
SV °C	323.305237
TV °C	-999999.000000

Device Setup

Process Variable Settings

Figure 131: Example of HART Basic View

Device Setup

Device Serial Number: 724793

Date: 22-Jan-2016

Descriptor: TEMPERATURE TRANSMITTER

Message: JUST TESTING

Figure 132: Example of a HART Device Setup Window

Figure 131: Example of HART Basic View and Figure 132: Example of a HART Device Setup Window present fields that are available for editing in Device Setup window and Process Variable Settings window.

Process Variable Settings

Transfer Function
Linear

Unit: °C Damping (s): 0.4

Sensor Serial Number: 823097

Range: 0 (0%) to 150 (100%) kPa

Range Limits: -200 ... 850 / 10

Figure 133: Example of a Process Variable Settings Window



Note: HART trimming is not supported when using MC6-T's Basic View. Use another Device Description when trimming a HART instrument.

Managing Digital Communication Instrument Configurations

General

Beamex offers a possibility to manage smart transmitter configurations using MC6-T and a free tool for personal computers: **Beamex MC6-T Fieldbus Configuration Viewer**. If applicable, the configurations may also be sent to **Beamex CMX Calibration Software**, as linked documents for a position.



Note: To be able to utilize this feature you need to have one or more of the necessary options installed (HART[®], FOUNDATION Fieldbus H1[™] or Profibus PA[™]).

Tools in MC6-T

Saving Configurations

When connected to a smart transmitter, open the menu to locate the **Configuration, Save As** menu option. When selected, MC6-T downloads all configuration data and after downloading it, prompts you to give the configuration a name. The default name is the transmitter's Tag name.

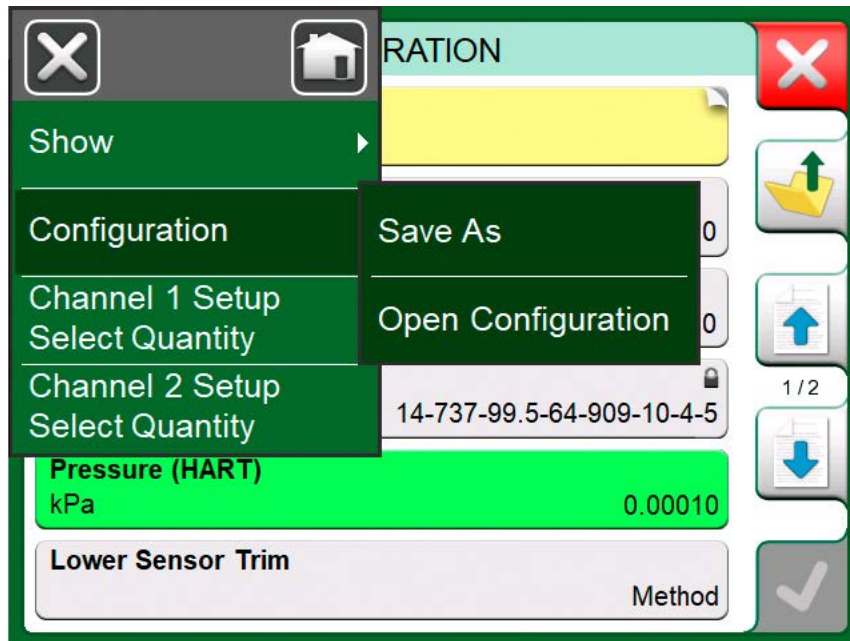

Figure 134: Configuration menu open

This feature is handy especially for customers that have analog DCS system and HART transmitters in the field. They can use this functionality to create a database with all the settings of their transmitters. If a transmitter breaks, all settings are stored in MC6-T (alternatively on a PC's hard disk) for future configuration of the new transmitter replacing the broken one.



Note: Please note that a saved configuration file cannot be written from MC6-T back to a transmitter.

Viewing/Managing Configurations

A list of saved configurations can be opened anywhere in **Communicator**. Open configurations option can be seen in the [Figure 134: Configuration menu open](#) and in the [Figure 135: Configuration options in protocol selection window](#) where no protocol is selected yet.

Selecting **Open Configuration** shows a list of saved configurations. The list shows the following information of each saved configuration file:

- The name of the file,
- Manufacturer / Model,
- Date / Time when saved and
- Protocol name.

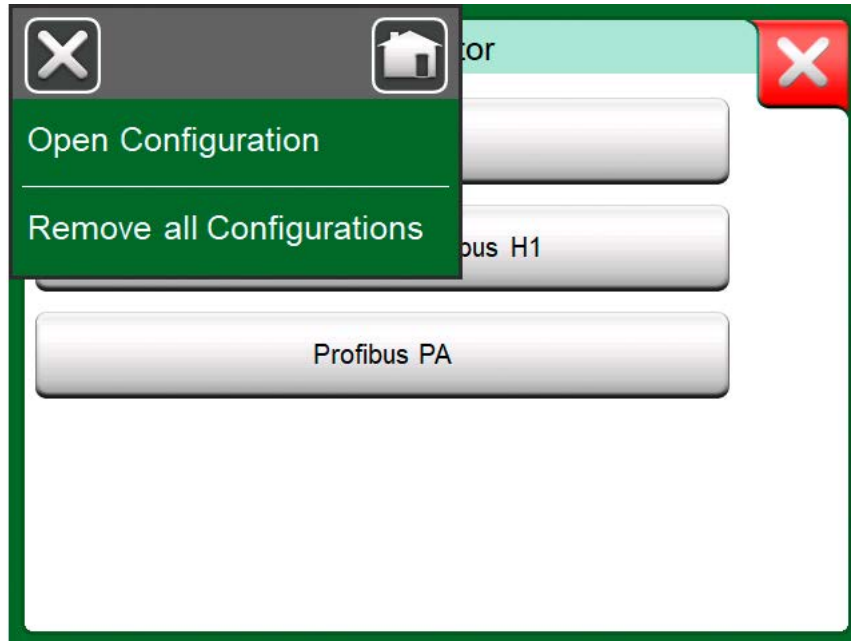

Figure 135: Configuration options in protocol selection window

You can sort the list of configurations according to your own needs with the help of the sorting tools available in the menu. Tap on a configuration to view the saved configuration data. Note that the data cannot be edited.

Beamex MC6 Fieldbus Configuration Viewer

Beamex MC6 Fieldbus Configuration Viewer is a free tool for Personal Computers with Windows[®] (version 8 and older) operating system. Download the Configuration Viewer software from Beamex's website: <https://www.beamex.com>. Look for **Download Center**.

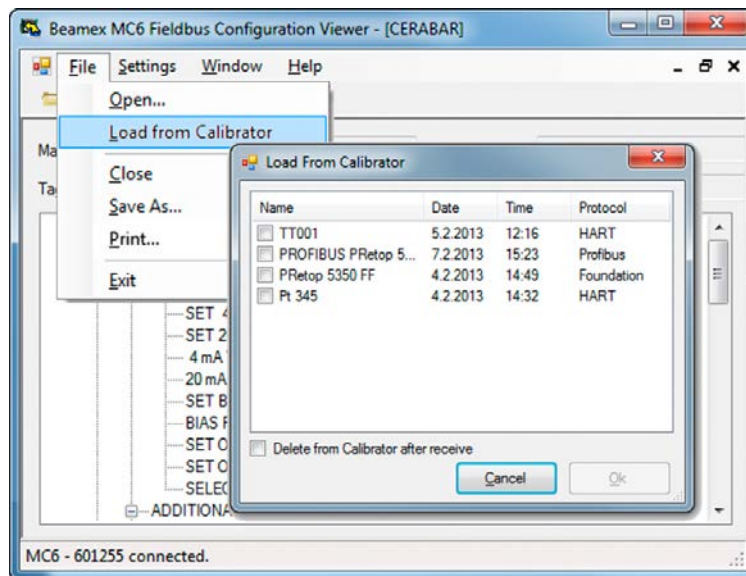

Figure 136: Beamex MC6 Fieldbus Configuration Viewer

Uploading Configurations

With **Beamex MC6 Fieldbus Configuration Viewer**, you can:

- Read configuration files from MC6-T
- View the configuration files
- Save the configuration files in PC (e.g. proprietary *.fc file).
- Print the configuration files

Linking Configurations to CMX

CMX includes a possibility to link documents to Positions/Devices etc. Use this feature to link the *.fc files to CMX. Double click the link to open it in the viewer.

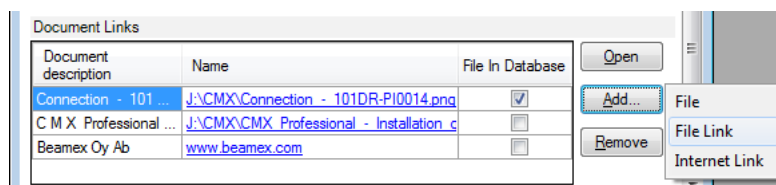

Figure 137: Document links window

Settings

Things discussed in this part:

- How to configure MC6-T to suit your own needs
- Briefly about recalibrating/adjusting MC6-T
- Optional security tool.

Settings overview

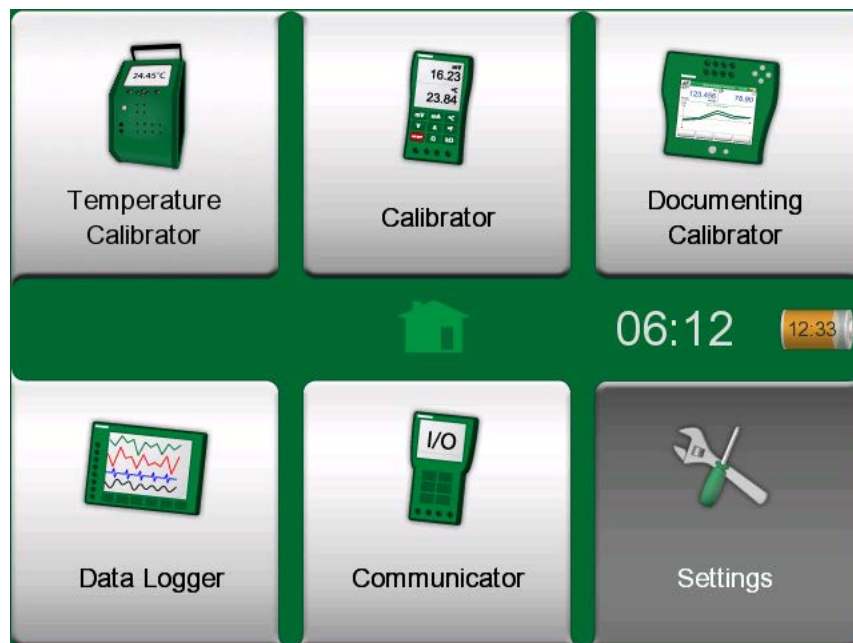

Figure 138: Home View with Settings selected

This operational mode allows you to configure MC6-T according to your own needs and also, recalibrate MC6-T. The following settings/configurations are available:

- **Language** for selecting user interface language.
- **About**. Information about installed modules, firmware options etc.
- **Power Management** for defining auto-off delays and display brightness. See also chapter [Power Management](#).
- **Sound Volumes** for setting volumes for different sounds MC6-T emits.
- **Date & Time**, including Time Zone selection and activating Daylight Saving Time. This setting is synchronized with the computer when communicating with CMX. See also chapter [Mobile Security Plus software option](#).
- **Regional Settings** for setting local net frequency and default values. See also chapter [Mobile Security Plus software option](#).
- **Owner** for entering owner information, shown in Home View.
- **Controller Presets**. Enabled if you have purchased controller communication options. More in chapter [Additional Information](#).
- **Maintenance** for recalibrating/adjusting MC6-T and setting calibration date. Also for the possibility to align the Touch Screen.
- **Documenting Calibrator**. Settings related to instrument calibration, e.g. is "**Save as Both**" allowed ("Save as Both" means a single calibration run may be saved both as As Found and As Left calibration.)



Note: If an instrument is sent from CMX, then CMX is the master system of these settings. In that case settings set in the calibrator does not matter.

- **HART, FOUNDATION Fieldbus and Profibus PA** for defining communication parameters to Digital Communication Instruments.
- **Network** for setting local area network parameters (for Beamex internal use only).
- **Temperature Block** opens a window for configuring how the heating and cooling is defined in the Temperature Block. This setting is also available in Temperature Calibrator's menu, see chapter [The Menu](#).

Each setting/configuration is self-explanatory once you have familiarized yourself with MC6-T's user interface. Configuration screens often have a menu option for recalling factory settings.



Note: MC6-T's calibration date can be set in **Maintenance** configuration window under **Change Module Data** setting. PIN code for setting the calibration date is **2010**. PIN code for MC6-T's **Adjust Calibrator** setting is device dependent and was shipped together with MC6-T.

Maintenance



Warning: There are no user-replaceable parts within the device. Do not open the enclosure!



Warning: Before any maintenance actions, switch off the Mains switch and disconnect the Mains cord. Detach all other cables as well.



CAUTION: In case an item is dropped inside the device, the device must be switched off and Mains cord disconnected immediately, after which the item must be removed by an authorized person.

Replacing the mains fuses

In order to replace the mains fuses follow steps below:



Warning: Switch off the device with the Mains switch and disconnect the Mains cord. The Mains cord must be disconnected to completely remove Mains Voltage from the device.

1. Remove the fuse holder caps using a screwdriver (fuse holder caps have a spring-load mechanism, press the cap gently and turn 30° counter-clockwise to open).
2. The fuses must be replaced with the **correct rating** and **type** according to the mains voltage region. See the specified rating and type on the sticker above the fuse holder.



Warning: Using fuses of wrong type may cause a hazard.

3. After replacing the fuses, attach the fuse holder caps to the equipment.
4. Connect the Mains cord and turn on the Mains switch. If the fuse blows again, ensure that you used correct type of fuse. If fuse type is correct and fuse still blows, send the device to the authorized service.

Overtemperature Protection Test Mode

MC6-T is equipped with an additional safety feature called **Overtemperature Protection Test Mode**. It gives a possibility to make sure that the power is disconnected from the Temperature Block in case it heats up over the maximum setpoint temperature.

To enter the **Overtemperature Protection Test** mode select **Settings** from the Home view. Tap **Maintenance** button, select **Change module data** option and provide the required PIN code: **5656**. After accepting the changes the device is in test mode.

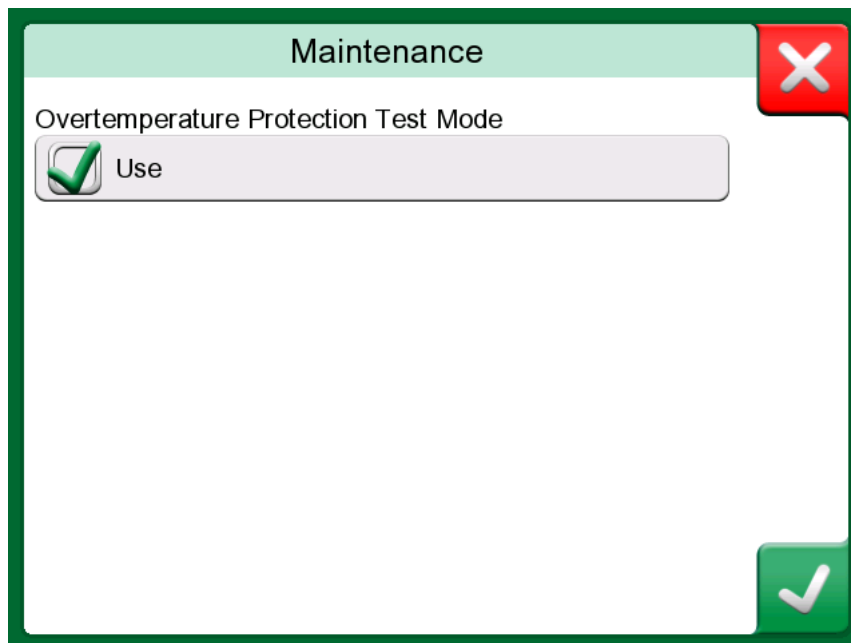

Figure 139: Overtemperature Protection Test Mode window

To test the feature, enable the temperature generation to maximum setpoint specific for your model. If the protective mechanism works properly, you will be prompted with a message shown in [Figure 140: Overtemperature Protection Test Mode prompt message](#). The power will be disconnected from the Temperature Block and the device will start cooling. To return to the normal operating mode, switch the Mains switch off and then back on, to clear the error condition.



CAUTION: If the maximum setpoint temperature stabilizes without an error message being shown, contact Beamex. Safe use of MC6-T is no longer ensured.

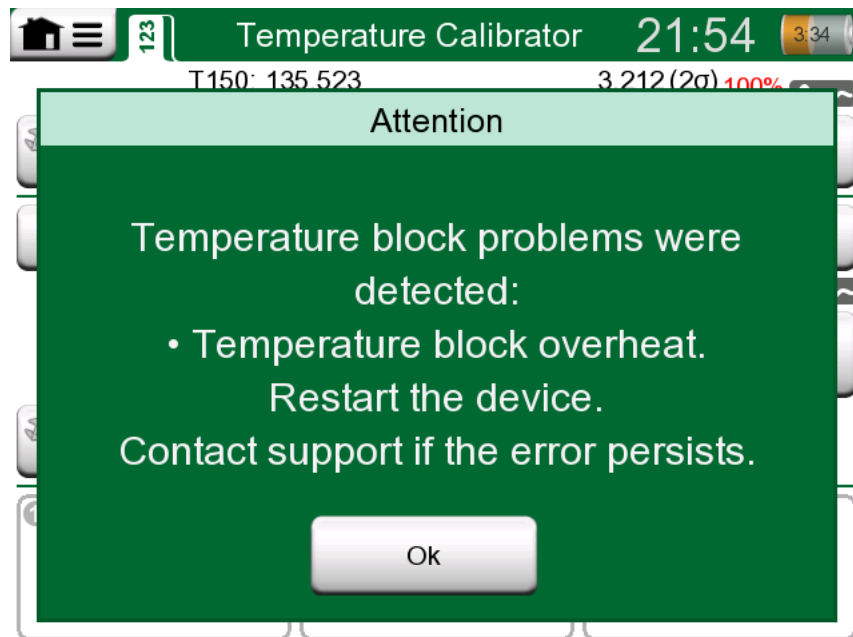

Figure 140: Overtemperature Protection Test Mode prompt message

Cleaning instructions



Warning: Disconnect the Mains cord and switch the Mains switch off before any cleaning actions. Make sure the device has fully dried up before using it again.



Note: Before using any cleaning or decontamination method, other than those recommended by Beamex, users should check with an Authorized Service Center to ensure the proposed method will not damage the equipment.

1. Inserts and inside of the Temperature Block

- Due to the high operating temperatures of the Temperature Block, the inserts should be removed after each use and buffed with a Scotch-Brite® pad or emery cloth. Make sure there are no remaining textile fibers on the insert or the Temperature Block surface.
- If there is an oxidation on the insert's outer surface it could cause the inserts to become jammed in the Temperature Block boring. Avoid this buildup by periodically buffing the inserts clean with an abrasive pad or fine sandpaper (over 400 grit).
- In case of oil contamination, Temperature Block boring and insert borings can be cleaned with mild alcohol-based solvent.

2. Other parts

- To clean the display, use a microfiber cloth. If necessary, use a mild detergent and remove it thoroughly when ready.
- If any of the other parts of the MC6-T requires cleaning, use a cloth dampened with a water-based or alcohol-based solvent. Alternatively, use low concentration of hydrogen peroxide or mild solution of tall oil soap (pine soap). Wait a few minutes and then clean using a cloth moistened with pure water. Never use any strong detergents.



Warning: Be careful not to get any liquid into the connectors, Mains switch and mains inlet socket! If any liquid gets inside of the device, contact Beamex. Safe use of MC6-T is no longer ensured.

Firmware Update

The quickest way to see if a new firmware version is available is checking out Beamex's web site (<https://www.beamex.com>). Look for **Downloads Center** and see what it says about MC6-T firmware versions and downloads. Also check for possible release notes accompanying the update file.

Transfer the update software to a USB stick (USB Flash Memory). Make sure MC6-T is **powered off**. Note that switching off the Mains switch takes the device to Standby mode, therefore it must be restarted and powered off from Calibrator power button after switching off the Mains switch. Connect the USB stick to the MC6-T's USB-A port.

Press and hold the **Left** and **Right** hardware arrow button and switch on the Mains switch. The update starts automatically. Follow the instructions seen on MC6-T's screen. The update is a multiphase process, so be patient.



Note: Updating MC6-T firmware does not erase any user entered data (instruments, calibration results, data logs etc.).

Supported file systems on USB Flash Memories are FAT 32 and FAT 16.

Recalibrating MC6-T

As any test and measurement device, we recommend to recalibrate MC6-T at regular intervals. Beamex recommends to recalibrate the device once

per year. This ensures accuracy and operating reliability throughout MC6-T's lifetime.

MC6-T is a high-accuracy calibrator and it should be recalibrated only at laboratories being able to offer sufficiently low uncertainty. Please note that all calibration laboratories are not able to offer required uncertainty. It is highly recommended that the calibration laboratory is accredited (ISO 17025) and has certified quality system in place.

For advice, please contact Beamex.



Note: If device is used in highly contaminated areas or the Temperature Block gets contaminated, device has to be sent for recalibration as its thermal properties may change.

By sending the calibrator to Beamex or your closest Beamex authorized service center for recalibration, you can be sure that your equipment will be cleaned, fully tested, loaded with the latest firmware/features, and recalibrated in a state-of-the-art calibration facility that meets the specifications of the calibrator.



Note: When setting MC6-T's calibration date, see chapter **Settings**.

Disposal of Waste Electrical and Electronic Equipment

Beamex and WEEE

Beamex is an environmentally conscious company developing products with a view to ensure that they are easy to recycle and do not introduce hazardous materials into the environment.

In the European Union (EU) and other countries with separate collection systems, waste from electrical and electronic equipment (WEEE) is subject to regulations.

EU WEEE Directive 2012/19/EU (the WEEE Directive) requires that producers of electronic equipment are responsible for the collection, reuse, recycling and treatment of WEEE which the Producer places on the EU market after August 13, 2005. The objective of this regulation is to preserve, protect and improve the quality of the environment, protect human health, and conserve natural resources.



The symbol visible above is printed on the product's rear cover sticker. It indicates that this product should be handed over to applicable collection point for the recycling of electrical and electronic equipment.

For more detailed information about recycling of this product, please contact your local representative or your waste disposal service.

Service and transportation instructions

Service of the MC6-T must only be performed by an authorized representative. There are no user-replaceable parts within the device. Do not open the enclosure!



Note: Whenever Mains cord must be replaced, select a cord with correct rating and type. Mains cord must have a protective earth.

Safe delivery for service

When sending MC6-T for service, place it in its original packing box, as received upon the delivery from Beamex. In all other cases use 40 mm softeners on all sides for safe delivery.

If your unit is equipped with the **Accessory Holder Kit** use the **Back Transport Support** during transportation to protect rear structures of the device. Slide the **Back Transport Support** into the **Accessory Holder Kit** as shown in [Figure 141: Back Transport Support attached in place for safe delivery](#).



Note: Before sending the unit for service, remember to remove the insert from the device and all accessories from the **Accessory Holder Kit**.



Figure 141: Back Transport Support attached in place for safe delivery

MC6-T660 model is equipped with **Transport Tap** shown in [Figure 142: MC6-T660 Transport Tap](#), to be used when sending the device for service. It can help to prevent damages to the Temperature Block that could occur during transportation in extreme conditions.



Note: If device is not in use, it is recommended to keep the **Transport Tap** inside the Temperature Block boring to avoid contamination.



Figure 142: MC6-T660 Transport Tap



Warning: Follow the regulations related to transporting devices containing Lithium Polymer Batteries.



Note: While transporting in the field, set the unit's handle to carrying position (see section [MC6-T Handle](#)) and treat the device with extra care.

For further information, contact Beamex. Contact information is on the prepages of this manual .

Resetting MC6-T

Sometimes you may want to reset/restart the calibrator. To do that, press and hold the Home and Enter keys for 7 seconds.



Note: MC6-T does not lose time, date or saved data during the reset. It just resets the main processor. Possible open files may however be lost.

Additional Information

Things discussed in this part:

- How to create custom pressure units, PRT sensors and transfer functions
- Basic Information on how to connect external devices like pressure controllers or temperature blocks to MC6-T.

User Defined Function Data

This section contains detailed information of some of MC6-T's more extensive features. The ones presented here are:

- [User Defined PRT/RTD Sensors](#)
- [User Defined Transfer Functions](#)
- [User Defined Pressure Units](#)
- [User Defined Steps Calibration Points](#)
- [Controller Communication](#)

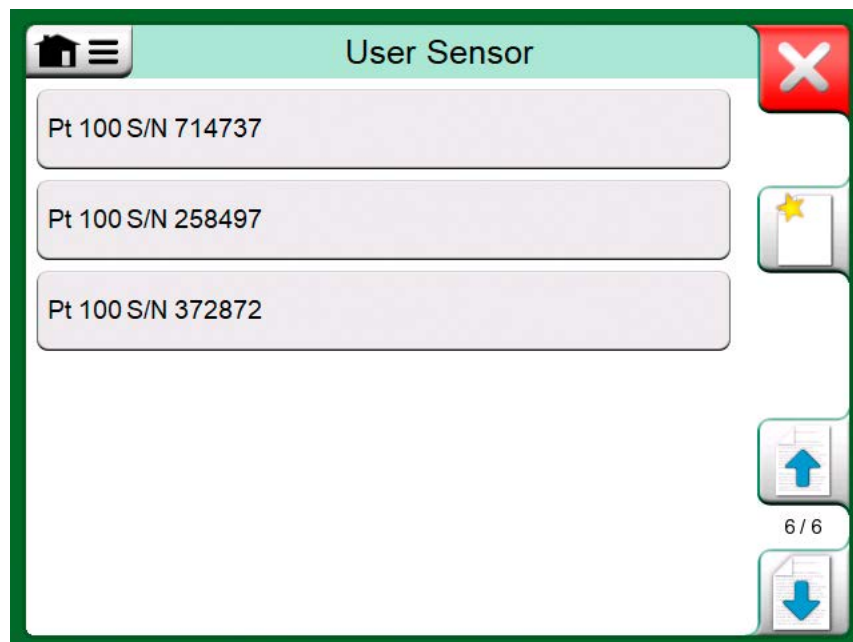

Figure 143: An example of a list of custom PRT sensors entered into MC6-T

Pages, where new user defined items can be created, contain a button as seen in [Figure 144: "Create New Instrument" button](#). Add as many items as is needed; more pages are added when the previous page is full.



Figure 144: "Create New Instrument" button



Note: These features are meant for experienced calibration technicians familiar with calibrators, especially MC6-T.

Deleting a user defined item stops a measurement/generation/simulation that was using it.

User Defined PRT/RTD Sensors

General

MC6-T offers a wealth of pre-entered standard Platinum Resistance Temperature (PRT) type RTD sensors. They are available wherever you may select **RTD Temperature** as the **Quantity**. However, when using a PRT sensor as a reference sensor, the available standard sensors aren't necessary of use. This is because reference sensors often have custom coefficients in, e.g. their **Callendar - van Dusen** or ITS-90 equation.



Note: If you are using CMX: Although it is possible to create and maintain the custom sensors in the MC6-T calibrator, it is highly recommended that the custom sensors (including their sensor coefficients) are created and maintained in CMX. This way the sensor information is centrally maintained and available for all calibrators supporting the sensors.

Figure 145: 1st configuration page

After the pages with pre-entered PRT sensors, there is room for user defined PRT sensors.

When a user defined PRT sensor is in use, the sensor button displays a warning symbol (triangle with an exclamation point inside) together with the name of the user defined PRT sensor. See an example below on how a user defined PRT sensor is shown in **Calibrator**. Other MC6-T's main functions display the user defined PRT sensors similarly.



Figure 146: User defined PRT sensor in Calibrator

When defining custom sensors, the **Sensor Calculation Formula** on the first configuration page is important. It affects what is available on further configuration pages. The following subchapters present the use of different formulas.



Note: For further information about **Sensor Calculation Formulas**, refer to literature related to calibrating Platinum Resistance Temperature sensors.

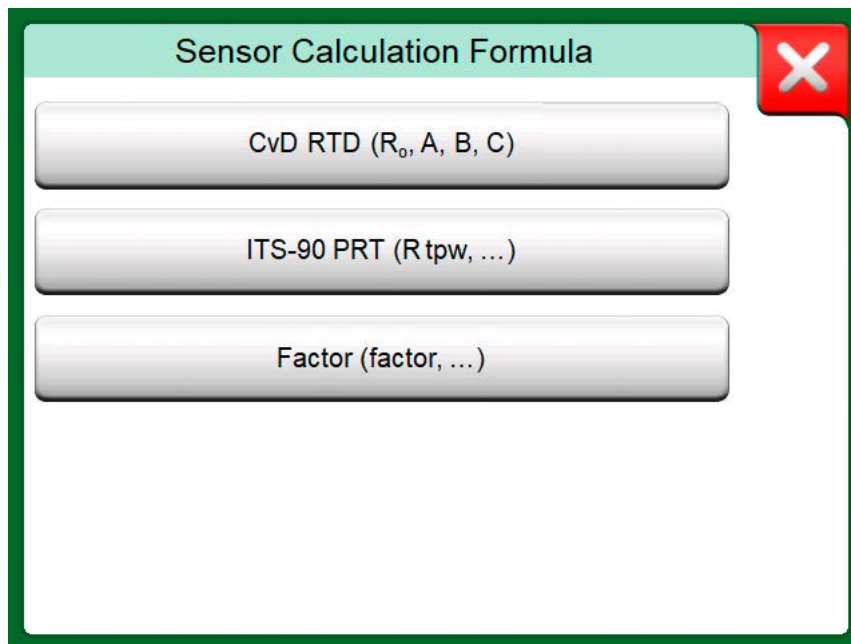

Figure 147: Sensor Calculation Formula options



Note: If you need to enter very small or big number into **Factor** field, open the menu available in **Soft Numeric Keypad**. When applicable, the menu contains a possibility to insert an exponent. This allows entering numbers in scientific notation, e.g. 5.775E-07.

Callendar van Dusen Formula for PRTs

When **CvD RTD (R₀, A, B, C)**, i.e. Callendar van Dusen formula is selected, sensor coefficients can be added, see [Figure 148: Example of configuration page for Callendar van Dusen constant and coefficients](#).

Figure 148: Example of configuration page for Callendar van Dusen constant and coefficients

Callendar van Dusen formula for PRTs can be defined using one of two equations, each with their own coefficients: A, B and C or alpha, delta and beta (α , δ and β). Additionally, a constant, R_0 , is needed to define the sensor.

MC6-T supports the use of the equation using coefficients A, B and C only. If your PRT's calibration certificate includes coefficients α , δ and β , use the following equations to convert them to A, B and C:

$$A = \alpha \cdot \left(1 + \frac{\delta}{100} \right) \quad B = \frac{-\alpha \cdot \delta}{10^4} \quad C_{T < 0} = \frac{-\alpha \cdot \beta}{10^8}$$

Figure 149: Equations for converting coefficients.

ITS-90 PRT Sensor

If your calibration certificate includes coefficients for ITS-90 deviation function (International Temperature Scale of 1990) PRT sensor, select **ITS 90 PRT (R tpw,...)** as the **Sensor Calculation Formula**. Then you may enter the constant, R tpw, and one or more coefficients: a_x , b_x ..., where the subscript x is 4 to 11, depending on the deviation formula used in the calibration.

If the coefficients in your calibration certificate are missing the subscripts, use the following table to find which coefficients you have been given.



Note: The definition of coefficient notations for the ITS-90 subranges is described in the NIST Technical Note 1265 "Guidelines For Realizing the International Temperature Scale of 1990".

Calibration ranges, corresponding coefficients and examples of calibration points:

<u>Calibration Ranges^(*)</u>	<u>Corresponding Coefficients</u>	<u>Example of fixed calibration points[#], °C</u>				
Negative (sub-)ranges:						
-189 ... 0 °C	a₄, b₄	-189.3442,	-38.8344,	0.01		
-38 ... 30 °C	a₅, b₅^(†)	-38.8344,	0.01,	29.7666		
Positive (sub-)ranges:						
0 ... 30 °C	a₁₁	0.01,	29.7666			
-38 ... 30 °C	a₅, b₅^(*)	-38.8344,	0.01,	29.7666		
0 ... 157 °C	a₁₀	0.01,	29.7666,	156.5985		
0 ... 232 °C	a₉, b₉	0.01,	156.5985,	231.928		
0 ... 420 °C	a₈, b₈	0.01,	231.928,	419.527		
0 ... 660 °C	a₇, b₇, c₇	0.01,	231.928,	419.527,	660.323	
0 ... 962 °C	a₆, b₆, c₆, d	0.01,	231.928,	419.527,	660.323, 961.78	

†) sub-range 5 is presented twice since it needs to be entered separately both for negative and positive sides.

*) the range limits in the adjacent list are rounded and shown as they are on MC6-T User Interface.

#) Not all calibration laboratories necessarily use the same points. These are for reference only.



Note: If your calibration certificate include two sets of coefficients. One for zero current and another for 1 mA current, enter the latter ones into MC6-T.

When selecting **ITS 90 PRT (R tpw,...)** as the **Sensor Calculation Formula**, the **Sensor Range** entered in the 1st configuration page defines how many additional **User Sensor** pages is added to MC6-T. If the range includes temperatures below zero, the total amount of configuration pages is four:

1. First page for general settings. See [Figure 145: 1st configuration page](#).
2. Second page for entering the **R tpw** constant value.
3. Third page for selecting the deviation formula for **negative** temperature subrange and entering the coefficients (a₄ and b₄ or a₅ and b₅).
4. Fourth page for selecting the deviation formula for **positive** temperature subrange and entering the coefficients (a₅, a₆, a₇ ... etc.).

The screenshot shows a software window titled "User Sensor" with a green border. At the top left is a home icon and a menu icon. The title bar contains "User Sensor" and a red close button with a white 'X'. Below the title bar, the text "Deviation Formula" is displayed above a text input field containing "0 ... 660 °C: a₇, b₇, c₇". Below this are three input fields for coefficients: "a" with the value "-2.1220485E-4", "b" with "-1.4071744E-4", and "c" with "5.0592624E-5". On the right side, there are navigation buttons: an up arrow, a "4 / 4" page indicator, and a down arrow. At the bottom right is a green checkmark button.

Figure 150: Examples of coefficients a_7 , b_7 and c_7

When no negative subrange is included in the calibration, the third page mentioned above is not included and the total amount of configuration pages is three.

Factor

The third way to customize an RTD sensor (not just PRTs but all types of RTDs) is using the **Factor**. This applies for sensors with the same relative error throughout the sensor's span, a sensor with an "offset" in its output.

How to Configure a User Sensor using Factor:

Select a standard **Sensor Type**. Then enter a **Factor** that offsets the standard temperature curve. A simple way of doing it is taking a standard RTD sensor with a 1 ohm resistance @ 0 °C, e.g. Pt1. Then enter the real resistance @ 0 °C as the **Factor**.

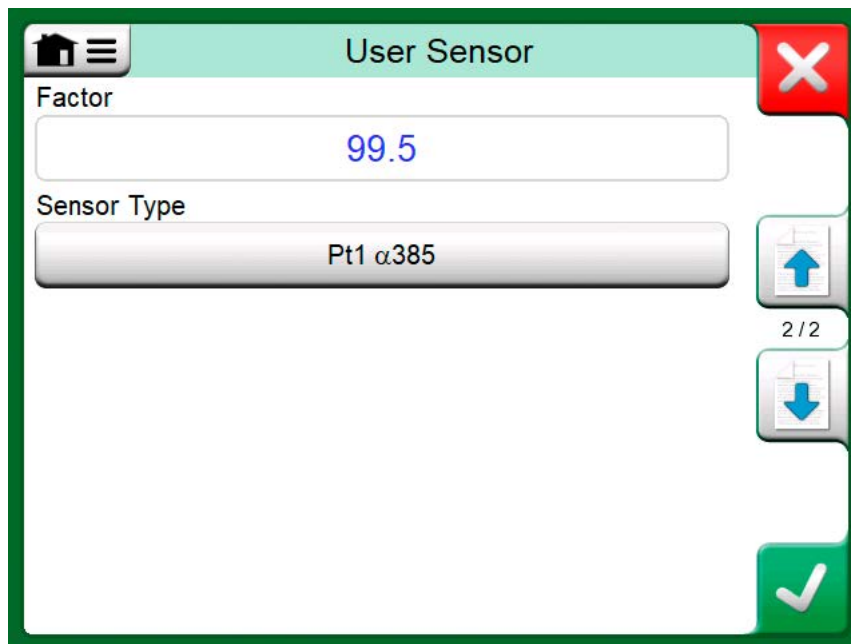



Figure 151: Configuration page for Factor

Check Sensor Conversion

MC6-T has a possibility to test sensors in the window presenting pre-entered and custom RTD sensors. The menu () in that window shows an option: **Test Sensor Conversion**.

The [Figure 152: Sensor test configuration and single point test page](#) presents the first of the **Test Sensor Conversion** pages. It allows you to select a sensor, the unit to be used and a possibility to test a single point. This is handy when you have entered coefficients of a custom sensor and want to test if the coefficients were entered correctly. Enter, e.g. a temperature that is in the calibration certificate and check if the calculated resistance in MC6-T is the same as on the calibration certificate. If yes, the entered coefficients in MC6-T are correct. If not, check the coefficients you entered.

Figure 152: Sensor test configuration and single point test page

The lower part of the first page allows you to define step sizes for tables seen on the second and third page. There you can see the sensor's temperature vs. resistance correlation (and vice versa) in table format.

User Defined Transfer Functions

Transfer Functions are available in Calibrator's **Scaling Tool** and in **instrument definitions** found in Documenting Calibrator.

When creating/selecting a user defined transfer function, tap on the **Transfer Function** button and browse to the **User Transfer Function** page.

The configuration consists of two (or more) pages as shown in [Figure 153: 1st configuration page](#) and [Figure 154: 2nd configuration page](#). The first page is for general definitions and the second for entering known transfer function points. If you enter more points than can be shown on one page, a further page is automatically added.

Figure 153: 1st configuration page

	Input (bar)	Output (mA)
1.	0.00000	4.00000
2.	1.00000	4.05000
3.	3.00000	4.78800
4.	5.00000	6.82000
5.	7.00000	11.0440
6.	Tap to Edit...	Tap to Edit...

Figure 154: 2nd configuration page

There are some "rules" on how to enter the transfer function points:

- The first point is always pre-entered and the values are not editable. They are the ranges' 0 % values.
- Manually entered points must be in increasing order.
- Last point must be exactly or greater than the range's 100 % value.

Also:

- The row number is a button. It opens a window where you may delete the current point or optionally add a row either before or after the current point.
- An added point gets default values: average values of preceding and following point.

User Defined Pressure Units

Wherever in MC6-T, when you use pressure as the **Quantity**, you may choose a pressure unit from a wealth of already available pressure units, divided into several pages. User defined pressure units may be added to the subsequent page(s).

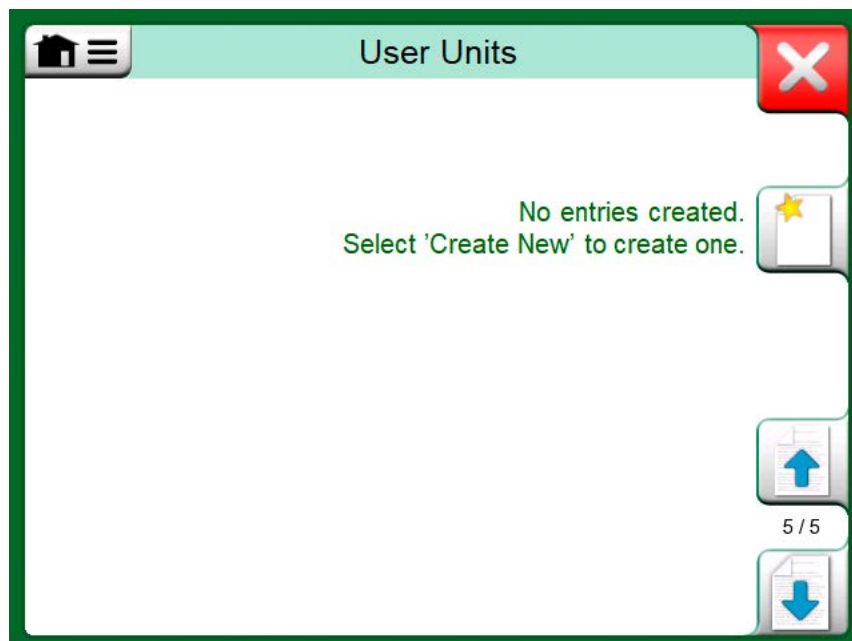

Figure 155: Page 5 of pressure units is reserved for user defined pressure units

In the configuration page, see [Figure 156: Configuration page](#), give the unit a descriptive name, select a **Reference Unit** and enter the **Factor**. The **Factor** is the relationship between the **Reference Unit** and the custom pressure unit. The **Reference Unit** may be any of the pre-entered pressure units available in MC6-T.

Figure 156: Configuration page

When a user defined pressure unit is in use, the unit button displays a warning symbol (triangle with an exclamation point inside) together with the name of the user defined pressure unit. See an example in [Figure 157: User defined pressure unit in Calibrator](#) on how a user defined pressure unit is shown in **Calibrator**. Other MC6-T's main functions display the user defined pressure unit similarly.

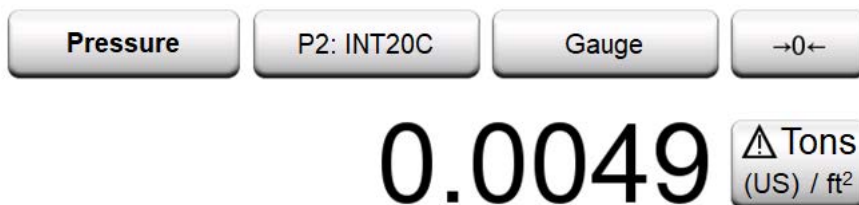

Figure 157: User defined pressure unit in Calibrator



Note: To select pressure as the Quantity, you need to have an optional internal barometric module and/or an external pressure sensor connected to MC6-T.

If you need to enter very small or big number into **Factor** field, open the menu available in **Soft Numeric Keypad**. When applicable, the menu contains a possibility to insert an exponent. This allows entering numbers in scientific notation, e.g. 5.775E-07.

User Defined Steps Calibration Points

These are available for instruments in **Documenting Calibrator** and also in Calibrator's **Step** tool. Use either **Calibration Points** or **Step Definition** button to modify its setting. In the opened window, browse to **User Test Points** page.

The configuration consists of two (or more) pages as shown in the [Figure 158: 1st configuration page](#) and [Figure 159: 2nd configuration page](#). The first page is for general definitions and the second for entering steps / calibration points. If you enter more points than can be shown on one page, a further page is automatically added.

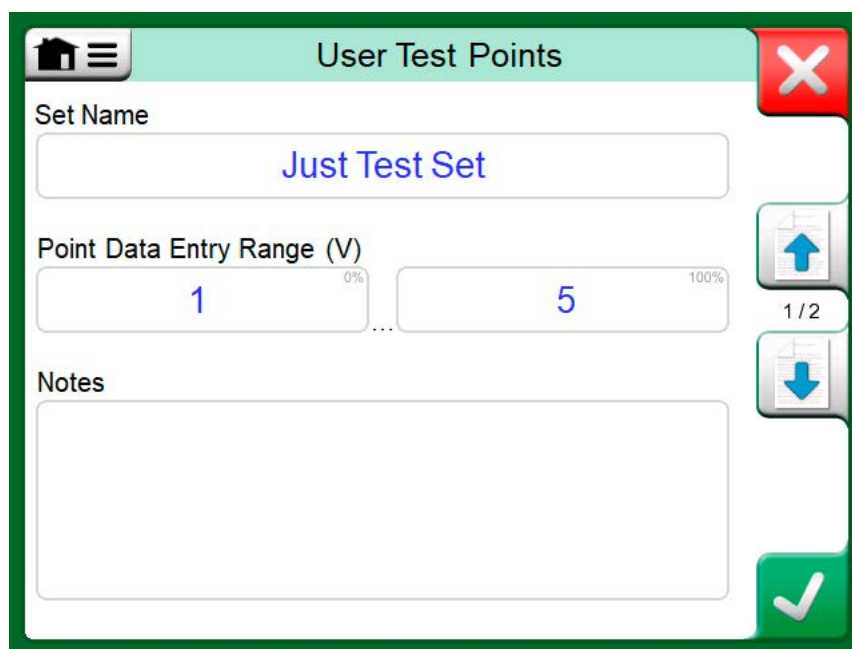

The screenshot shows a software window titled "User Test Points". At the top left is a home icon and a menu icon. The title bar contains the text "User Test Points" and a red close button with a white "X". Below the title bar, there is a "Set Name" label followed by a text input field containing "Just Test Set". Underneath is the "Point Data Entry Range (V)" label, followed by two input fields. The first field contains "1" and has "0%" to its right. The second field contains "5" and has "100%" to its right. Below these fields is a "Notes" label and a large empty text area. On the right side of the window, there are three buttons: a red close button at the top, an up arrow button with "1 / 2" below it, and a down arrow button. At the bottom right corner, there is a green checkmark button.

Figure 158: 1st configuration page

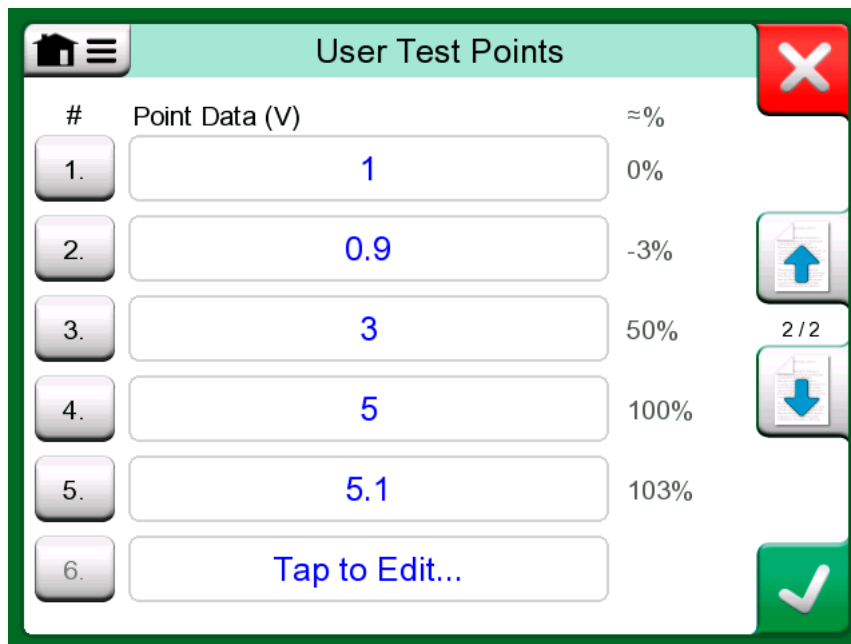

Figure 159: 2nd configuration page

There are no "rules" in what kind of values are entered. They may be outside given point data entry range and need not be in any strict order. See [Figure 159: 2nd configuration page](#).

Also:

- The row number is a button. It opens a window where you may delete the current point or optionally add a row either before or after the current point.
- An added point gets a default value: Average value of preceding and following point.

Controller Communication

MC6-T's communication with External Controllers (Pressure and Temperature) connected to the USB-A port is optional. Check what options your MC6-T has from the **Settings** window. Tap on the **About** button and browse to page with **Installed Options** information.

What Can be Done With Controller Communication

Ways of using an External Controller with MC6-T:

- **Controller** (full use).

MC6-T uses the External Controller to set and measure the signal. Controller can be taken into use in MC6-T's Port/Function list in MC6-T's **Temperature Calibrator**, **Calibrator**, **Documenting Calibrator** and **Data Logger**. See example in [Figure 160: Pressure Port / Function list with Controller and Measurement available](#). In **Beamex CMX Calibration Software**, this corresponds to **Input Method Controlled and Measured**.

- **Measurement** (only).

The External Controller acts like an external measuring device (comparable to an External Pressure Module). This feature needs to be activated in MC6-T's **Controller Presets** window. More of **Controller Presets** window further on. When activated, Measurement is available in Port/Function lists in MC6-T's **Temperature Calibrator**, **Calibrator**, **Documenting Calibrator** and **Data Logger**. See [Figure 160: Pressure Port / Function list with Controller and Measurement available](#).

- **Control** (only).

MC6-T uses the External Controller to set calibration points. It is measured by some other means, e.g. MC6-T's Pressure Module. This is available in MC6-T's Documenting Calibrator only. See [Figure 161: Instrument input settings with Control \(only\) selected](#). In CMX, this corresponds to Input Method Controlled.

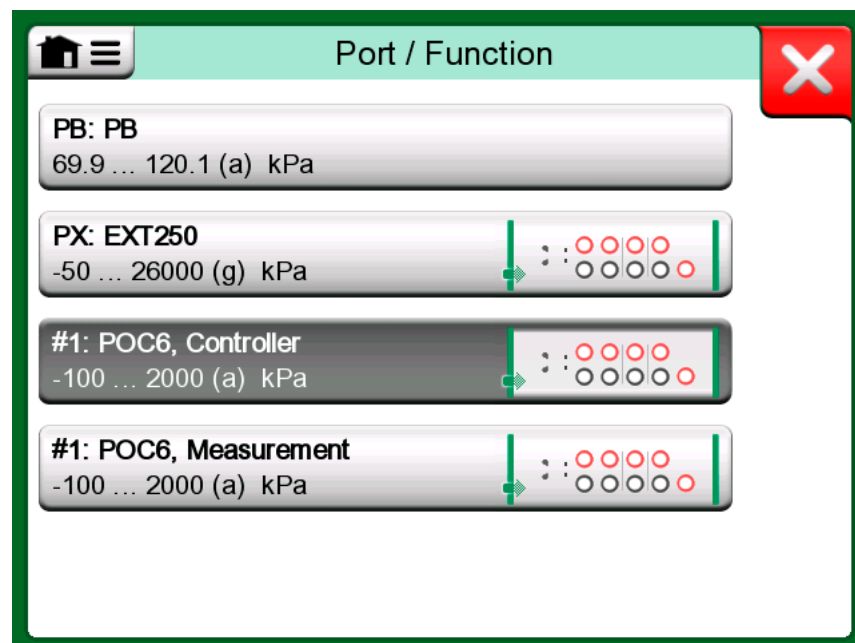

Figure 160: Pressure Port / Function list with Controller and Measurement available

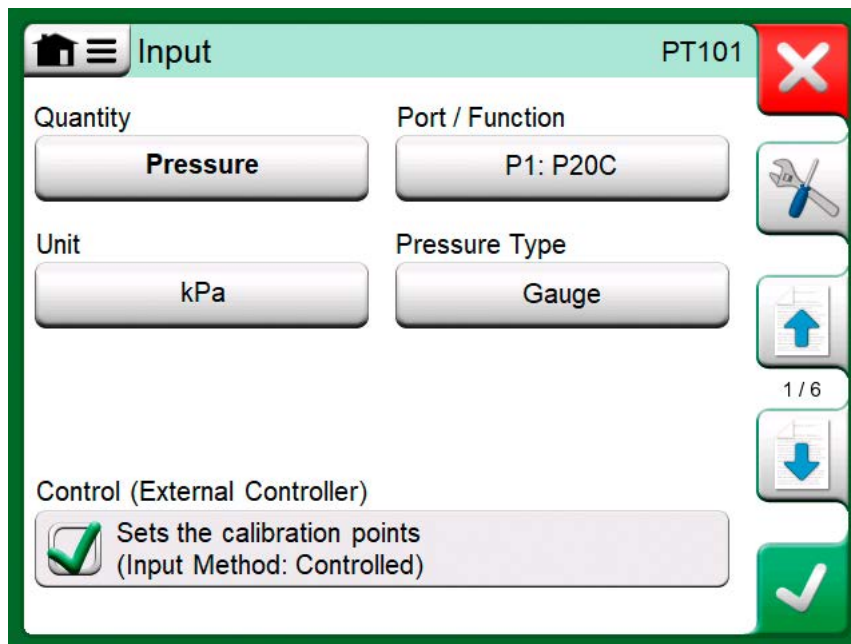

Figure 161: Instrument input settings with Control (only) selected



Note: When connecting a Beamex FB or MB Temperature Dry Block to MC6-T, ensure that both devices are up and running before connecting a communication cable and invoking communication between them.

Configuring Controller Communication

Before utilizing External Controllers, both the communication cable / driver and the controller itself need to be configured in MC6-T. This should be done using the **Controller Preset** window available in MC6-T's main function **Settings**. MC6-T supports up to four presets. Each of the presets create a pair of a **Connection Interface** (communication cable / driver) and a **Controller Type**. See [Figure 162: Example of a Controller Preset](#).

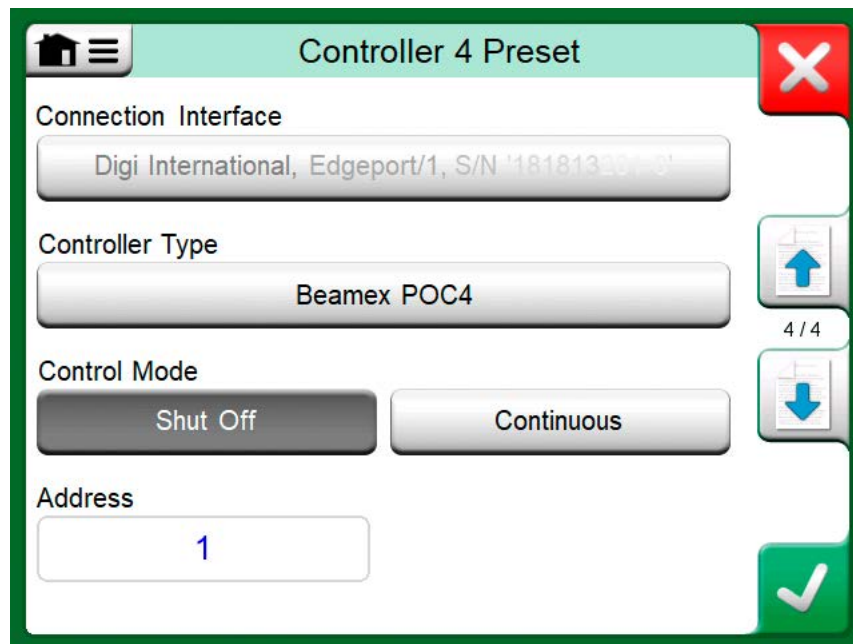

Figure 162: Example of a Controller Preset

The menu in a **Controller Preset** window contains further tools for defining the communication. One of the menu items is **Enable Measurement Port**, defining whether the is controller also used as a measuring device. Menu selections may be individual for each preset.

When an External Controller is connected and configured, it is available as any port in MC6-T's user interface.



Note: If you run into communication problems, check the communication settings in the connected controller. They may have been changed from the controller's default values. MC6-T always uses the controller's default values.

The Controller Preset window's menu includes an option to view the **Communication Log**. In the Communication Log window you may choose the log format: binary or text.

Changing Controller During Calibration

In Documenting Calibrator, you may need to change the controller during calibration. This, e.g. because a temperature controller's span is not useful throughout the measurement span of the instrument to be calibrated.

Change the controller as follows:

1. During calibration, open the **Documenting Calibrator's** Menu.
2. Select option **Instrument Input**.
3. In the **Instrument Input** window, tap on the button that invokes the controller change procedure.
4. Follow the instruction on the screen.

Index

A

About this manual.....	8
Accessories.....	37
Additional Info.....	59
Alarms.....	59
Approvals.....	
EMC Approval.....	11
Auto-Off Settings.....	139

B

Back Transport Support.....	147
Batteries.....	23
Buttons.....	
Accept.....	28
Check Boxes.....	28
Close.....	28
Hardware Focus Indicator.....	28
Menu.....	28

C

Calibration.....	
Changing the Pressure Module.....	95
Customizing Mapping.....	100
Deleting Results.....	98
Instrument Overview.....	90
Mapping Instrument Data.....	98
Saving Results.....	91
Selecting a Fieldbus Parameter.....	124
Selecting a HART Parameter.....	123
Viewing Results.....	97
Calibration Software.....	32, 37, 74
Calibrator operational mode.....	71
Check Boxes.....	28
Communication Settings.....	139
Communicator.....	
Connections.....	118
Editing a Parameter.....	125
List of Instruments.....	121
Selecting a Variable.....	122
Selecting the Instrument.....	120
Trimming a Fieldbus Instrument.....	129
Trimming a HART Instrument.....	126
Configurations (Smart Transmitters).....	
Managing.....	135
Saving.....	134
Viewing.....	135
Connections.....	
Fieldbus/HART.....	118
General.....	39
Thermocouple.....	57

Connectors.....	
Ethernet.....	22
Front.....	19
Left side.....	19, 22
USB.....	22
Controller Communication.....	
Changing Controller.....	167
Configuring Pressure Controllers.....	166
Configuring Temperature Controllers..	166
Controller Settings.....	139
Current Generation.....	53
Current Measurement.....	44
Customizing Mapping Instrument Data.....	100

D

Damping.....	59
Data Logger.....	
Configuring.....	106
Deleting Results.....	111
Saving Configurations.....	109
Saving Results.....	111
Selecting a Fieldbus Parameter.....	124
Selecting a HART Parameter.....	123
Starting.....	110
Transferring Results to a PC.....	113
Viewing Results.....	111
Date & Time Format.....	139
Date/Time Fields.....	28
Delivery for service.....	147
Display.....	23
Disposing MC6-T.....	145
Documenting Calibrator.....	73

E

Editable Fields.....	
Date/Time.....	28
Numeric.....	28
Text.....	28
Entering Numbers.....	47, 48
Ethernet, Connector.....	22
External Controllers.....	166
External Pressure Modules.....	43
External Reference Junction.....	57

F

Factory Hierarchy.....	75, 88
Fieldbus Instruments.....	96, 115
Fieldbus Settings.....	139
Firmware Update.....	144
Fixed Reference Junction (Temperature)...	57

FOUNDATION Fieldbus™	115
Frequency Measurement	45
Function Info	59

G

Generation (see also Simulation)	
Changing the generated value	47
Current	53
Frequency	55
Pulses	56
Voltage	54

H

Hand Pumps	37
Hardware Focus Indicator	28
HART Settings	139
HART®	96, 115
Headers, described	8

I

Inheriting Settings	39
Instrument	76
Instrument List	75
Internal Reference Junction	57

L

Language	139
Leak Test	59
Left Side Connectors	19
Loop supply	44

M

Maintenance	139
Managing Smart Transmitter Configurations	135
Manual Reference Junction (Temperature)	57
Mapping Instrument Data	98
MC6 Fieldbus Configuration Viewer	136
MC6-T	
Approvals	11
Firmware	28
Hardware	19
Recalibrating	144
Resetting	149
Service	147
Measurement	
Calibrator	71
Current	44
Frequency	45
Pressure	43
Pulse Counting	46

Resistance	41, 42
RTD	41
Switch Sensing	47
Temperature	40, 41
Thermocouple	40
Voltage	45
Memory	23
Menu Button	28
Mobile Security Plus	103, 103

N

Numbers, Entering	47, 48
Numeric Fields	28
Numeric keypad	47

O

Options	
Mobile Security Plus Tool	103
Software	33

P

PC Communication	32, 37, 74
Plant Structure	75, 88
Power Management	139
Pressure Controllers	37, 164
Pressure Measurement	
External Pressure Modules	43
Zeroing a Pressure Module	44
PROFIBUS PA™	115
PRT Sensors	
Callendar van Dusen	154
Factor customization	157
ISO 90	155
Testing Custom Sensors	158
User Defined	152
Pulse Counting	46
Pulse Generation	56

Q

Quick Access Buttons	59
----------------------	----

R

Ramping	59
Recalibrating MC6-T	144
Reference Junction	40
Reference Junction Connections	57
Regional Settings	139
Resetting MC6-T	149
Resistance Measurement	42
Resistance Simulation	54
Resolution	59

Results (Calibration).....	
Deleting.....	98
Saving.....	91
Viewing.....	97
RTD Measurement.....	41
RTD Simulation.....	52

S

Safety.....	13
Safety precautions.....	13
Saving Smart Transmitter Configurations..	134
Scaling.....	59
Service MC6-T.....	147
Settings.....	139
Simulation (see also Generation).....	
Changing the simulated value.....	47
Resistance.....	54
RTD.....	52
Thermocouple.....	51
Software Options.....	33
Sounds.....	139
Spinner.....	48
Stability Test.....	59
Standard Accessories.....	9
Starting a Data Log.....	110
Stepping.....	59
Supply Voltage.....	44
Switch Sensing.....	47
Symbols, Alarms.....	59

T

Temperature Blocks.....	37
Temperature Controllers.....	164
Temperature Measurement.....	40, 41
Testing Leakage/Stability.....	59
Text Fields.....	28
Thermocouple Connections.....	57
Thermocouple Simulation.....	51
Tools.....	
Additional Info.....	59
Alarms.....	59
Damping.....	59
Function Info.....	59
Leak/Stability Test.....	59
Quick Access Buttons.....	59
Ramping.....	59
Resolution.....	59
Scaling.....	59
Stepping.....	59
Touch Screen Display.....	23
Transferring Data Log Results to a PC.....	113
Transport Tap.....	147
Transportation.....	147
Trimming a Fieldbus Instrument.....	129
Trimming a HART Instrument.....	126
Typographical conventions.....	9

U

Unpacking.....	9
USB Connectors.....	22
User Defined Calibration Points.....	163
User Defined Function Data.....	151
User Defined Pressure Units.....	161
User Defined PRT Sensors.....	152
User Defined Steps.....	163
User Defined Transfer Functions.....	159
User interface.....	28

V

Viewing Smart Transmitter Configurations	135
Voltage Generation.....	54
Voltage Measurement.....	45
Volume of Sounds.....	139

W

Warnings.....	
Electrical.....	16
Pressure Measurement.....	16, 17
Use of Communicator.....	118
WEEE.....	145

Z

Zeroing a Pressure Module.....	44
--------------------------------	----

